



***Industrial Hose & Accessories***

***Be More***

***FLEXIBLE***

2024/25 Product Catalog



## TABLE OF CONTENTS

Quick Selection Guide .....	4
flexDUCT™ .....	8
flexFLO™ .....	13
flexFOOD™ .....	19
flexLINE™ .....	22
flexVAC™ .....	26
flexCHEM™ .....	30
flexVAPOR™ .....	34
flexFUEL™ .....	37
Accessories .....	40

### Appendix

Chemical Resistance .....	44
Application Guide .....	46
Minimum Bending Radius .....	48
Temperature Effects .....	49
Usage and Storage Suggestions .....	49
Precautionary Statement .....	50
Claims .....	50
Returned Goods Policy .....	50
Warranty .....	51





# FROM THE EDITOR

Welcome to the 2024/25 Kanaflex Product Guide!

Since our last publication, Kanaflex has undergone significant changes. We've welcomed new ownership, rebranded, and reorganized our entire product line. With so many exciting updates, we wanted to offer some tools on this page to help you easily navigate our new product guide.











On the right, you'll find a key to our quick selection guide icons. These icons are used throughout the guide to help you easily identify the key features of our hoses.

Below is our new Flex Structure, which we use to organize our product offerings. All of our hoses are categorized into clearly defined sections. This simplified structure is designed to make finding the Kanaflex hose you need a breeze.

**Editor**  
James Rand

# FEATURE ICONS

Look for these icons on every product page to find the features you are looking for when deciding on a hose for your next job.

-  **Cold Weather Flexible**  
(-40°F or lower)
-  **Easy Drag**
-  **Abrasion Resistance**
-  **Full Vacuum**  
(no lower than 29.8 Hg)
-  **Static Wire**
-  **High Temperature**  
(200°F or higher)
-  **Static Dissipating**
-  **High Working Pressure**  
(100 psi or higher)
-  **Food Grade**
-  **High Flexibility**  
(Based on Bend Radius)
-  **UV Resistant**

# FLEX STRUCTURE

## flex**FLO**™

These hoses move materials and water

## flex**FOOD**™

These hoses move food grade material

## flex**CHEM**™

These Hoses move chemicals

## flex**VAC**™

These hoses are used to vacuum

## flex**POWER**™

These hoses move petroleum

## flex**VAPOR**™

These hoses move air

## flex**DUCT**™

These hoses are ducting hoses

## flex**LINE**™

These hoses are reinforced

# Quick Selection Guide

Hose	Page	Description
<b>flexDUCT™</b>	<b>8</b>	
flexDUCT™ PP (KNDT)	<b>9</b>	Interlocking polypropylene general ducting and blower hose
flexDUCT™ 150 (150CL)	<b>9</b>	Lightweight PVC blower and ducting hose
flexDUCT™ U 150 (150 UDH)	<b>10</b>	Polyurethane medium-duty blower and ducting hose
flexDUCT™ 155 (155 GY)	<b>10</b>	Heavy-duty PVC blower and ducting hose
flexDUCT™ 620 (620WD)	<b>11</b>	General ducting and blower hose with metal wire helix
flexDUCT™ 625 (625WD WS)	<b>11</b>	General ducting and blower hose with metal wire helix and external wear strip
flexDUCT™ 630 (630ED)	<b>12</b>	Medium-duty blower and ducting hose
flexDUCT™ 660 (660YD)	<b>12</b>	Heavy-duty duct hose with “safety yellow” helix for high visibility
<b>flexFLO™</b>	<b>13</b>	
flexFLO™ lite 100 (100CL)	<b>14</b>	General water suction and discharge hose
flexFLO™ lite 100 CW (100 CWFLX)	<b>14</b>	Cold weather water suction and discharge hose
flexFLO™ lite U 100 (100 UCLRD)	<b>15</b>	Medium-duty polyurethane dry material handling hose
flexFLO™ 110 (110CL/110GR)	<b>15</b>	Heavy-duty water suction and discharge hose
flexFLO™ 112 (112CL/112AG)	<b>16</b>	Economical heavy-duty water suction and discharge hose
flexFLO™ U 113 (113UVCLBK)	<b>16</b>	UV resistant all weather suction and discharge hose
flexFLO™ 114 (114CL/114GR)	<b>17</b>	Lightweight water suction and discharge hose
flexFLO™ 116 (116Blue)	<b>17</b>	Cold weather water suction and discharge hose
flexFLO™ SPA (SPA WHITE)	<b>18</b>	Flexible PVC spa hose
flexFLO™ lite 100 (100Blue)	<b>18</b>	Cold weather water suction and discharge hose
<b>flexFOOD™</b>	<b>19</b>	
flexFOOD™ lite 200 (200SFG)	<b>20</b>	Food grade suction and discharge hose
flexFOOD™ lite 200 ST (ST 200SFG)	<b>20</b>	Medium-duty food grade suction and discharge hose
flexFOOD™ 210 (210HFG)	<b>21</b>	Heavy-duty food grade suction and discharge hose
flexFOOD™ Milk 212 (212 MK)	<b>21</b>	Heavy-duty food grade suction and discharge milk hose

**NOTE:**

Over flexing or repeated flexing of hose within 18” of fitting is a common cause of hose failure. Installing a 12”-14” section of our Banding Coil at the end of the hose should be considered. *Kanaflex will not be responsible for damage to hose due to over flexing.*

Construction	Working Pressure (72°F, P.S.I.)	Size Range
Interlocked polypropylene	—	2-1/2" to 12"
Flexible PVC, rigid PVC helix, smooth bore, corrugated O.D.	2 to 6	2-1/2" to 8"
Polyurethane medium-duty blower and ducting hose	3 to 9	2-1/2" to 8"
Flexible PVC, rigid PVC helix, smooth bore, corrugated O.D.	10 to 20	1-1/2" to 8"
EPDM rubber, metal wire helix, smooth bore, slightly corrugated O.D.	3 to 12	2" to 12"
EPDM rubber, metal wire helix, wearstrip, smoothbore, corrugated O.D.	3 to 12	2-1/2" to 12"
EPDM rubber, polypropylene helix, smooth bore, corrugated O.D.	—	2" to 8"
EPDM rubber, polypropylene helix, smooth bore, corrugated O.D.	3 to 9	4" to 12"
Flexible PVC, rigid PVC helix, smooth bore, corrugated O.D.	30 to 50	1" to 10"
Cold weather PVC, rigid PVC helix, smooth bore, corrugated O.D.	20 to 25	3" to 6"
Flexible polyurethane lined PVC tube, rigid PVC helix, smooth bore, PVC corrugated O.D.	30 to 40	2" to 6"
Flexible PVC, rigid PVC helix, smooth bore, smooth O.D.	28 to 86	3/4" to 8"
Flexible PVC, rigid PVC helix, smooth bore, smooth O.D.	50 to 80	1-1/4" to 4"
Flexible PVC blended with polyurethane, rigid PVC helix, smooth bore, smooth O.D.	55 to 86	1" to 3"
Flexible PVC, rigid PVC helix, smooth bore, smooth O.D.	45 to 65	1-1/4" to 4"
Flexible PVC, rigid PVC helix, smooth bore, smooth O.D.	21 to 70	1" to 8"
Flexible PVC, rigid PVC helix, smooth bore, smooth O.D.	60 to 100	1/2" to 2"
Cold weather PVC, rigid PVC helix, smooth bore, corrugated O.D.	20 to 40	1" to 8"
Produced entirely of compounds in compliance with FDA and 3-A non toxic specifications, flexible PVC, rigid PVC helix, smooth bore, corrugated O.D.	30 to 50	1" to 4"
Produced entirely of compounds in compliance with FDA and 3-A nontoxic specifications, flexible PVC, rigid PVC helix, multi-strand copper static grounding wire, smooth bore, corrugated O.D.	30 to 45	1-1/2" to 4"
Produced entirely of compounds in compliance with FDA and 3-A nontoxic specifications, flexible PVC, rigid PVC helix, smooth bore, corrugated O.D.	55 to 86	3/4" to 4"
Produced entirely of compounds in compliance with FDA and 3-A nontoxic specifications, flexible PVC, rigid PVC helix, smooth bore, corrugated O.D.	62 to 66	1-1/2" to 3"

# Quick Selection Guide

Hose	Page	Description
<b>flexLINE™</b>	<b>22</b>	
flexLINE™ CW (KLCWB)	<b>23</b>	Reinforced cold weather suction and discharge hose
flexLINE™ Blue (KLCWB)	<b>23</b>	Reinforced cold weather suction and discharge hose
flexLINE™ SR (KLSR)	<b>24</b>	Heavy-duty suction and discharge hose
flexLINE™ U Food Grade (STKLUFG)	<b>24</b>	Heavy-duty reinforced polyurethane food-grade suction and discharge hose
flexLINE™ Food Grade (KLFW)	<b>25</b>	Heavy-duty reinforced food grade suction and discharge hose
<b>flexVAC™</b>	<b>26</b>	
flexVAC™ lite 180 AR (180BL)	<b>27</b>	Lightweight abrasion resistant blower and suction hosewear strip
flexVAC™ lite 180 MVAR (180MV)	<b>27</b>	Medium-duty abrasion resistant suction and discharge hose
flexVAC™ 180 AR (180AR)	<b>28</b>	Heavy-duty abrasion resistant suction and discharge hose
flexVAC™ 180 STAR (180STAR)	<b>28</b>	Heavy-duty abrasion resistant suction and discharge hose with static wire
flexVAC™ 180 HR (180HR)	<b>29</b>	High-temperature abrasion resistant suction hose
flexVAC™ U Boom ST (STKB)	<b>29</b>	Heavy-duty abrasion resistant wet and dry material handling hose
flexVAC™ lite U Boom ST (STKB LITE)	<b>30</b>	Medium-duty wet and dry material remote hose with grounding wire
flexVAC™ Max (KPAT)	<b>30</b>	Heavy-duty high pressure suction and discharge hose
<b>flexCHEM™</b>	<b>31</b>	
flexCHEM™ 220 (ST 220RS)	<b>32</b>	Heavy-duty abrasion resistant chemical suction and discharge hose
flexCHEM™ 300 (300GR/EPDM)	<b>32</b>	All purpose chemical suction and discharge hose
flexCHEM™ 390 (390 SD)	<b>33</b>	Heavy-duty reinforced chemical suction and discharge hose
<b>flexVAPOR™</b>	<b>34</b>	
flexVAPOR™ lite U 101 (101PS UVOR)	<b>35</b>	General vapor, water suction and discharge hose
flexVAPOR™ 120 ST (ST120 VP)	<b>35</b>	Gasoline vapor recovery hose
flexVAPOR™ U 120 ST (ST120 UACVR)	<b>36</b>	All purpose tank truck and terminal vapor recovery hose
<b>flexFUEL™</b>	<b>37</b>	
flexFUEL™ 120 ST (ST120 HP)	<b>38</b>	Heavy-duty tank truck drop hose
flexFUEL™ lite 120 ST (ST120 LT)	<b>38</b>	All purpose tank truck drop hose
flexFUEL™ U 120 ST (ST120 UAPDH)	<b>39</b>	All purpose polyurethane tank truck drop hose

Construction	Working Pressure (72°F, P.S.I.)	Size Range
Flexible cold weather PVC, rigid PVC helix, synthetic braiding, smooth bore, corrugated O.D.	50 to 70	2" to 6"
Flexible cold weather PVC, rigid PVC helix, synthetic braiding, smooth bore, corrugated O.D.	30 to 75	1-1/2" to 10"
Flexible PVC, rigid PVC helix, synthetic braiding, smooth bore, corrugated O.D.	28 to 110	1-1/2" to 12"
Flexible static dissipative polyurethane liner and PVC, rigid PVC helix, synthetic braiding, no direction required, smooth bore, PVC corrugated O.D. with copper grounding wire.	70 to 75	4" to 6"
Produced entirely of compounds in compliance with FDA and 3-A nontoxic specifications, flexible PVC, rigid PVC helix, synthetic braiding, smooth bore, corrugated O.D.	70 to 110	1-1/2" to 6"
SBR rubber blended with static carbon black, rigid PVC helix, smooth bore, corrugated O.D.	8 to 18	2-1/2" to 8"
SBR rubber with carbon black, rigid PVC helix, smooth bore, corrugated O.D.	8	5" to 6"
SBR rubber blended with static carbon black, rigid PVC helix, smooth bore, corrugated O.D.	25 to 45	1-1/4" to 12"
SBR rubber blended with static carbon black, rigid PVC helix, smooth bore, with copper wire, corrugated O.D.	10 to 20	2" to 4"
EPDM rubber, polyethylene helix, metal helical wire, smooth bore, corrugated O.D.	30	4" to 8"
Flexible high abrasion polyurethane liner, rigid PVC helix, synthetic braiding, no direction required, smooth bore, extra UV inhabitant PVC corrugated O.D. with static dissipating materials and copper grounding wire.	60 to 75	4" to 8"
Lightweight, flexible, and abrasion-resistant, with a static copper wire for dissipating charges. Suitable for hydro-vac trucks, vacuum trucks, general construction with rock, gravel, sand, and crushed concrete, as well as industrial vac equipment, roof vac, dry fertilizer, and petcoke.	70 to 100	3" to 6"
SBR rubber blended with static dissipating carbon black	140	4" to 6"
SBR rubber with carbon black, rigid PVC helix, smooth bore, smooth O.D.	23 to 50	1-1/2" to 6"
All purpose chemical suction and discharge hose	23 to 50	1" to 6"
EPDM rubber, polyethylene helix, synthetic braiding, smooth bore, corrugated O.D.	90 to 100	1-1/4" to 3"
Flexible PVC, rigid PVC helix, smooth bore, corrugated O.D.	30 to 35	2-3/4" to 4-1/2"
Nitrile rubber, rigid PVC helix, smooth bore, corrugated O.D., static grounding wire	10 to 20	2" to 4"
Lightweight clear static dissipating non-permeable polyurethane with smooth bore, corrugated O.D., rigid PVC helix, static grounding wire	7 to 9	2" to 4"
Nitrile rubber static dissipating tube, rigid PVC helix, synthetic braiding, smooth bore, static grounding wire, corrugated O.D.	150	3" to 4"
Nitrile rubber static dissipating tube, rigid PVC helix, synthetic braiding, smooth bore, static grounding wire, corrugated O.D.	65	2" to 4"
Non-permeable polyurethane inner and outer tube with synthetic braiding, smooth bore, corrugated O.D., PVC helix for easy drag, clear static dissipating tube and multi-strand copper static wire	65	2" to 4"

flexDUCT™

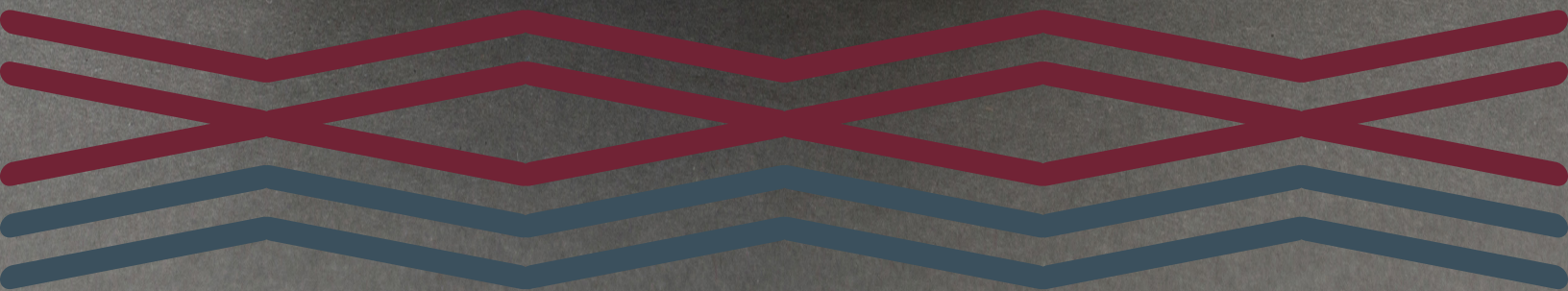
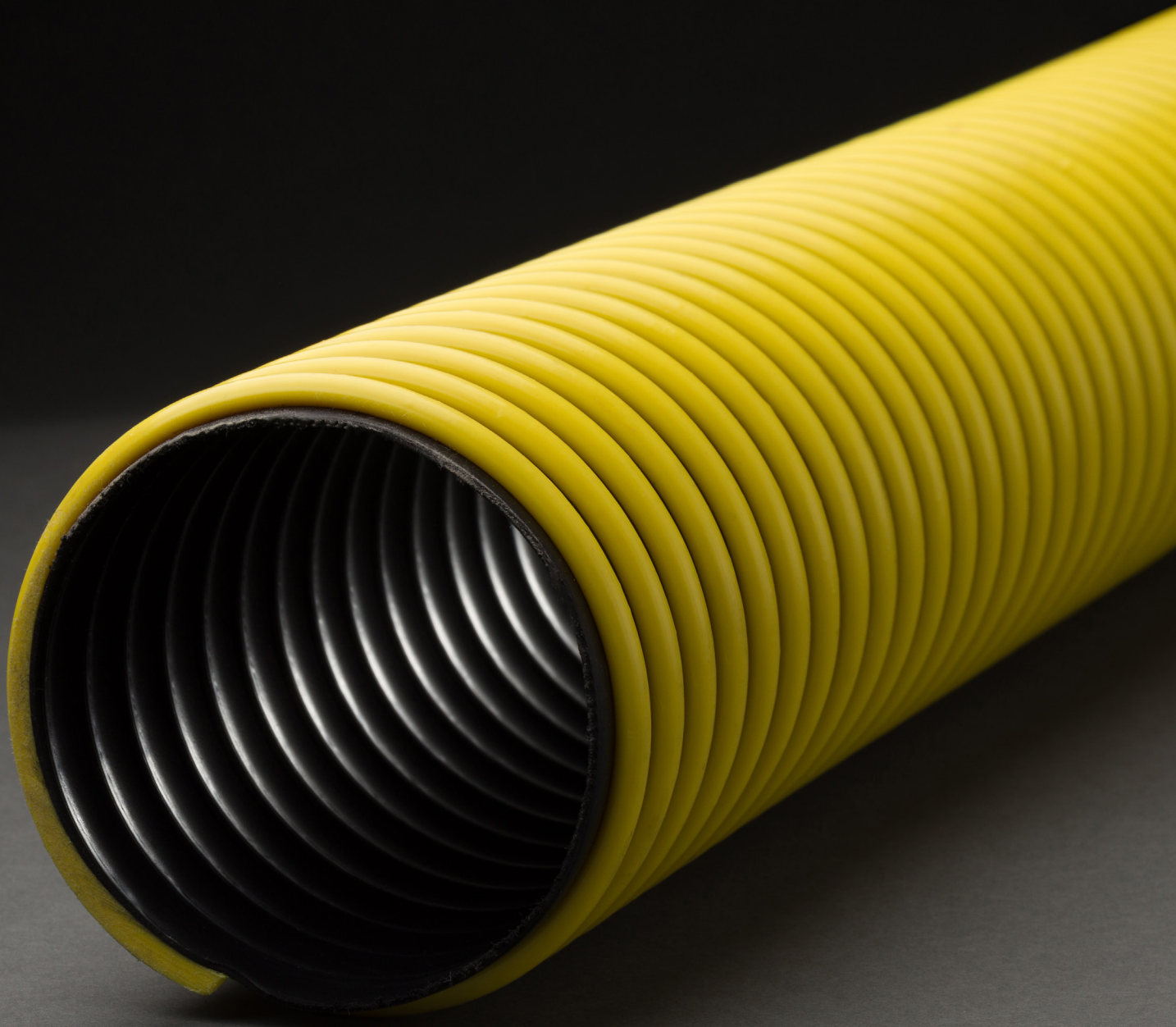



# flexDUCT™ PP (KNDT)

## Polypropylene general ducting and blower hose

*A versatile solution with interlock construction for adjustable inside diameter. Ideal for general ducting, spot coolers, clean room venting, and fume/dust removal, as well as elbows for rigid pipe.*

### FEATURES

Interlock construction allows the inside diameter to be changed by twisting the hose, while still holding its shape.

### APPLICATIONS

General ducting and blower hose used for spot coolers, clean room venting, fume/dust removal, elbows for rigid pipe

### CONSTRUCTION

Interlocked polypropylene

### TEMP. RANGE

-13°F to 180°F

### NOTE

Not a food grade hose

### AVAILABLE SIZES

2-1/2, 3, 4, 5, 6, 8, 10, 12

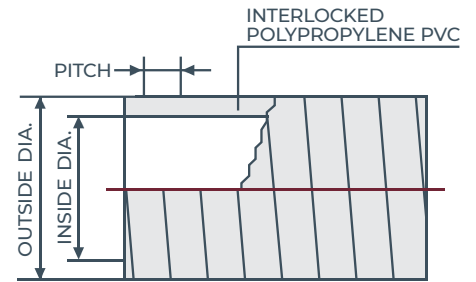
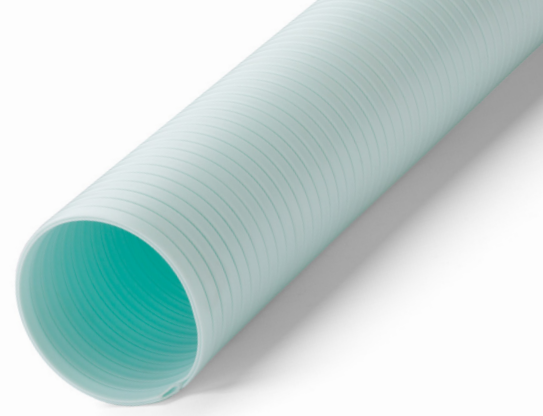

# flexDUCT™ 150 (150CL)

## Lightweight blower and ducting hose

*A versatile solution for light-duty applications. Flexible and lightweight, it features an external helix for easy drag and a smooth bore for precise flow. Ideal for general ducting needs, including ventilation, handling grass clippings, leaves, dust, and fumes.*

### FEATURES

Flexible and lightweight. External helix provides easy drag. The smooth bore allows for precise flow because no irregularities in the wall can cause interruptions.

### APPLICATIONS

Light-duty general ducting for ventilation and grass clippings, leaves, dust and fumes.

### CONSTRUCTION

Flexible PVC, rigid PVC helix, smooth bore, corrugated O.D.

### TEMP. RANGE

-13°F to 140°F

### NOTE

Not a food-grade hose

### AVAILABLE SIZES

2-1/2, 3, 4, 5, 6, 7, 8

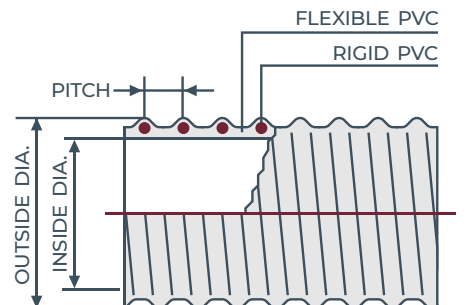

# flexDUCT™ U 150 (150 UDH)

Medium-duty polyurethane blower and ducting hose

*A versatile solution for medium-duty applications. Lightweight, flexible, and abrasion-resistant, it's designed for various ducting and blower needs.*

## FEATURES

Lightweight and flexible. External helix provides for easy drag. Abrasion-resistant polyurethane and smooth bore eliminate material build-up.

## APPLICATIONS

Medium-duty ducting and blower applications. For use with light to medium weight abrasives, leaf and grass collection, cotton pickers, mulch blowing, dust and sawdust collection.

## CONSTRUCTION

Flexible clear polyurethane, rigid PVC helix, smooth bore, corrugated O.D.

## TEMP. RANGE

-40°F to 140°F

## NOTE

Not a food-grade hose

## AVAILABLE SIZES

2-1/2, 3, 4, 5, 6, 7, 8

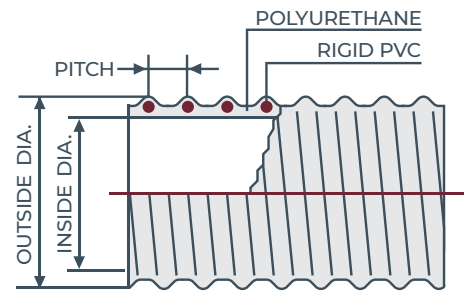
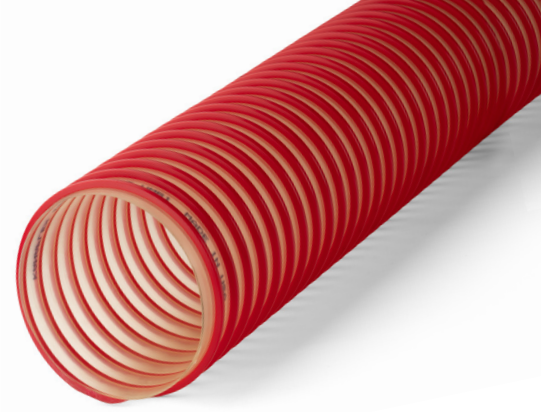

# flexDUCT™ 155 (155 GY)

Heavy-duty blower and ducting hose

*A reliable solution for the collection of grass, leaves, dust, and fumes. Clear sidewall for visual inspection, smooth bore for precise flow, and easy drag with an external helix.*

## FEATURES

Clear sidewall permits visual check of material flow. The smooth bore allows for precise flow because no irregularities in the wall can cause interruptions. Smooth bore also promotes drainability. External helix provides for easy drag.

## APPLICATIONS

Heavy-duty blower and ducting hose for collection of grass, leaves, dust, and fumes

## CONSTRUCTION

Flexible PVC, rigid PVC helix, smooth bore, corrugated O.D.

## TEMP. RANGE

-13°F to 140°F

## NOTE

Not a food-grade hose

## AVAILABLE SIZES

1-1/2, 2, 2-1/2, 3, 4, 5, 6, 8

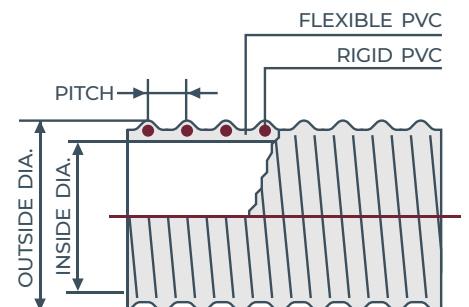

# flexDUCT™ 620 (620WD)

General ducting and blower hose

A versatile solution rated to 220°F. Combining abrasion resistance with flexibility, it's ideal for lightweight abrasives like sawdust, grass clippings, street refuse, and cotton pickers. Constructed with EPDM rubber, a metal wire helix, a smooth bore, and a slightly corrugated outer diameter.

## FEATURES

Rated to 220°F. Abrasion resistant yet very flexible. 100% rubber sidewall (no fabric).

## APPLICATIONS

For use with lightweight abrasives such as sawdust, grass clippings, street refuse and cotton pickers.

## CONSTRUCTION

EPDM rubber, metal wire helix, smooth bore, slightly corrugated O.D.

## TEMP. RANGE

-40°F to 220°F

## AVAILABLE SIZES

2, 2-1/2, 3, 4, 5, 6, 7, 8, 10, 12

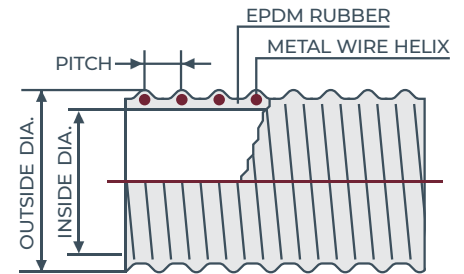

# flexDUCT™ 625 (625WD WS)

General ducting and blower hose

A versatile solution with a wear strip for light dragging. Combining abrasion resistance with flexibility, it's ideal for lightweight abrasives like sawdust, grass clippings, street refuse, and cotton pickers. Constructed with EPDM rubber, a metal wire helix, a smooth bore, and a slightly corrugated outer diameter.

## FEATURES

Abrasion resistant yet very flexible. 100% rubber sidewall (no fabric). Also, comes with an outer metal wear strip for light dragging. External helix provides easy drag. The smooth bore allows for precise flow because no irregularities in the wall can cause interruptions.

## APPLICATIONS

For use with lightweight abrasives such as sawdust, grass clippings, street refuse and cotton pickers.

## CONSTRUCTION

EPDM rubber, metal wire helix, metal wear strip, smooth bore, slightly corrugated O.D.

## TEMP. RANGE

-40°F to 220°F

## AVAILABLE SIZES

2-1/2, 3, 4, 5, 6, 7, 8, 10, 12

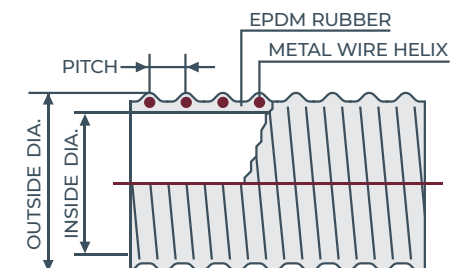

# flexDUCT™ 630 (630ED)

## Medium-duty ducting and blower hose

*A durable solution with a thicker sidewall for enhanced abrasion resistance. Designed for medium-duty blower and ducting applications, including hay baling, street refuse, grain dust, cotton pickers, wood chips, straw blowing, and leaf and grass collection. Constructed with EPDM rubber, a polypropylene helix.*

### FEATURES

Thicker sidewall for more abrasion resistance. External helix acts as a scuff guard. 100% rubber sidewall (no fabric).

### APPLICATIONS

Medium-duty blower and ducting applications such as hay baling, street refuse, grain dust, cotton pickers, wood chips, straw blowing, leaf and grass collection

### CONSTRUCTION

EPDM rubber, polypropylene helix, smooth bore, corrugated O.D.

### TEMP. RANGE

-40°F to 158°F

### AVAILABLE SIZES

4, 6, 8

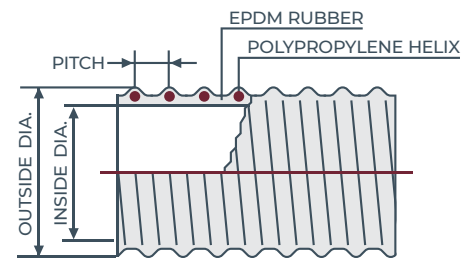

# flexDUCT™ 660 (660YD)

## Heavy-duty duct hose

*An exceptional solution for demanding applications. With a smooth bore for higher laminar flow, a robust “safety yellow” helix for visibility and abrasion resistance, it’s perfect for heavy-duty ducting needs like cleaning, grass and leaf collection, cement dust recovery, blast cabinet dust collection systems, and grain auger downspouts. Constructed with EPDM rubber, and a polypropylene helix.*

### FEATURES

Smooth bore for higher laminar flow. Extra heavy-duty “safety yellow” helix for high visibility and superior external abrasion resistance for “dragging” applications. 100% rubber sidewall (no fabric).

### APPLICATIONS

Heavy-duty ducting applications such as duct cleaning, commercial grass and leaf collection, cement dust recovery for floor finishing,

blast cabinet dust collection systems, and grain auger downspouts

### CONSTRUCTION

EPDM rubber, polypropylene helix, smooth bore, corrugated O.D.

### TEMP. RANGE

-40°F to 158°F

### AVAILABLE SIZES

4, 5, 6, 8, 10, 12

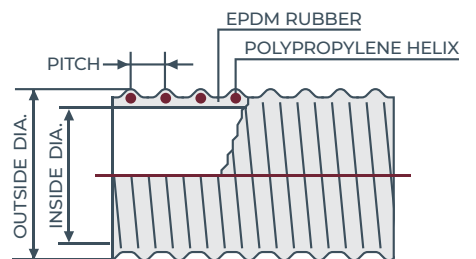

flexFLO™

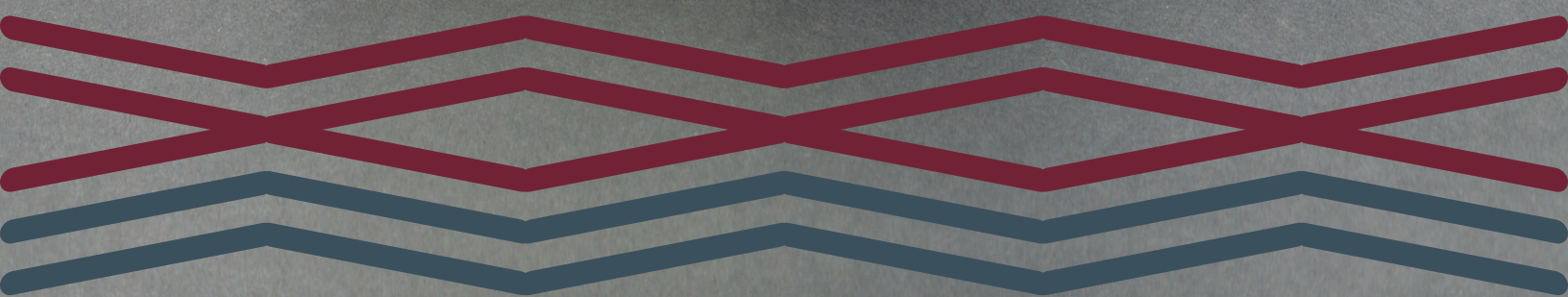
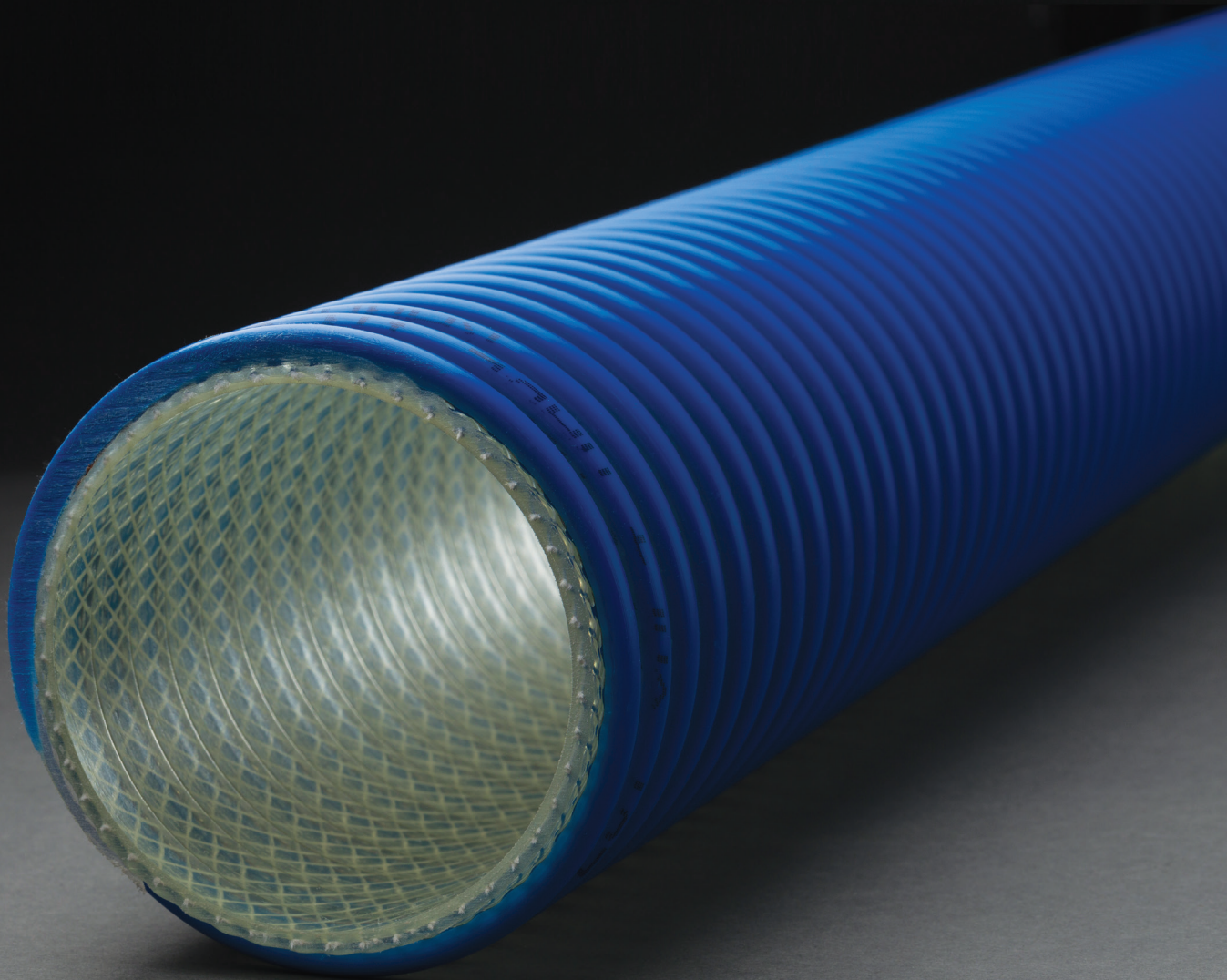

# flexFLO™ lite 100 (100CL)

## General water suction and discharge hose

*An adaptable solution for diverse applications. Constructed with flexible PVC, it offers easy drag with an external helix, clear sidewall for visual inspection, and smooth bore for precise flow and drainability. Ideal for water pumping on construction sites, as well as general use in agricultural and marine industries.*

### FEATURES

Lightweight and flexible hose constructed with flexible PVC. External helix provides for easy drag. Rated for both suction and discharge. Clear sidewall permits visual check of material flow. The smooth bore allows for precise flow because no irregularities in the wall can cause interruptions. Smooth bore also promotes drainability.

### APPLICATIONS

The general water and suction hose that can be used for water pumping on construction sites and also serves as a general used hose in both the agricultural and marine industries.

### TEMP. RANGE

-13°F to 140°F

### CONSTRUCTION

Flexible PVC, rigid PVC helix, smooth bore, corrugated O.D.

### NOTE

Not a food-grade hose

### AVAILABLE SIZES

1, 1-1/4, 1-1/2, 2, 3, 4

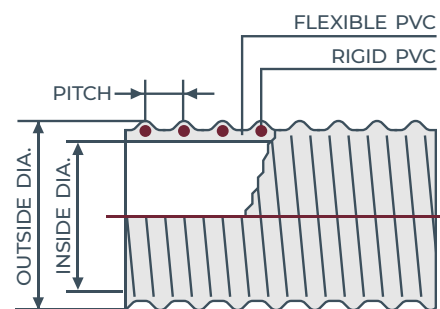

# flexFLO™ lite 100 CW (100 CWFLX)

## Cold weather water suction and discharge hose

*A versatile solution for demanding cold conditions. Constructed with cold weather PVC, it offers flexibility, easy drag with an external helix, and suitability for both suction and discharge. Ideal for water pumping on construction sites and widely applicable in agricultural and marine industries.*

### FEATURES

Lightweight and flexible hose constructed with cold weather PVC, making it perfect for the most demanding cold conditions. External helix provides for easy drag. Rated for both suction and discharge. Clear sidewall permits visual check of material flow.

### APPLICATIONS

The general water and suction hose that can be used for water pumping on construction sites and also serves as a general used hose in both the agricultural and marine industries.

### TEMP. RANGE

-40°F to 140°F

### CONSTRUCTION

Cold weather PVC, rigid PVC helix, smooth bore, corrugated O.D.

### ACCESSORIES

Banding coil, Powerlock clamp

### NOTE

Not a food-grade hose

### AVAILABLE SIZES

1, 1-1/2, 2, 3, 4, 5, 6

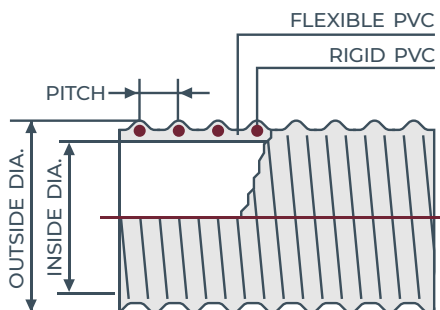

# flexFLO™ lite U 100 (100 UCLRD)

Medium-duty polyurethane dry material handling hose

*Engineered for sub-zero flexibility. With a clear polyurethane-lined PVC tube, it is ideal for dry material pneumatic conveying, plastic pellet and powder transfer (non-static), and diverse agricultural applications.*

## FEATURES

Lightweight and flexible in sub-zero temperatures. Clear polyurethane lined PVC tube provides abrasion resistance, permits visual check of material flow, prevents material build up, and provides quiet operation.

## APPLICATIONS

Dry material pneumatic conveying systems and plastic pellet and powder transfer when static is not a concern. Agricultural applications, such as air seeders, abrasive material vacuum systems, and industrial vac equipment.

## CONSTRUCTION

Flexible polyurethane lined PVC tube, rigid PVC helix, smooth bore, PVC corrugated O.D.

## TEMP. RANGE

-13°F to 140°F

## ACCESSORIES

Banding coil, Powerlock clamp

## NOTE

Not a food-grade hose

## AVAILABLE SIZES

1, 1-1/4, 1-1/2, 2, 2-1/2, 3, 4, 5, 6

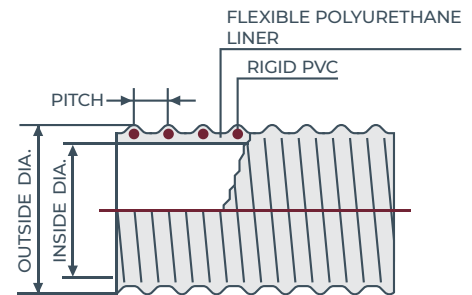

# flexFLO™ 110 (110CL/110GR)

Heavy-duty water suction and discharge hose

*A versatile solution for agricultural, marine, and fish suction applications. Lightweight, flexible, and featuring a clear sidewall for visual inspection, it ensures precise flow in temperatures from -13°F to 140°F.*

## FEATURES

Lightweight and flexible water and suction hose. Clear sidewall permits visual check of material flow. The smooth bore allows for precise flow because no irregularities in the wall can cause interruptions. Smooth bore also promotes drainability.

## APPLICATIONS

Heavy-duty water and suction hose with multiple agricultural applications including, air seeder, fertilizer sprayer, foam markers, irrigation, and manure spreading. Also useful in fish suction applications.

## TEMP. RANGE

-13°F to 140°F

## CONSTRUCTION

Flexible PVC, rigid PVC helix, smooth bore, smooth O.D.

## NOTE

Not a food-grade hose

## AVAILABLE SIZES

3/4, 1, 1-1/4, 1-1/2, 2, 2-1/2, 3, 4, 5, 6, 8

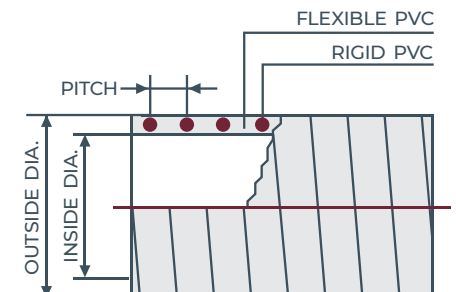

# flexFLO™ 112 (112CL/112AG)

Economical heavy-duty water suction and discharge hose

*An ideal solution for various agricultural applications such as air seeder, fertilizer sprayer, foam markers, irrigation, and manure spreading. Lightweight, flexible, and featuring a clear sidewall for visual inspection, it ensures precise flow and optimal drainability.*

## FEATURES

Lightweight and flexible water and suction hose. Clear sidewall permits visual check of material flow. The smooth bore allows for precise flow because no irregularities in the wall can cause interruptions. Smooth bore also promotes drainability.

## APPLICATIONS

Economical water and suction hose with multiple agricultural applications including, air seeder, fertilizer sprayer, foam markers, irrigation, and manure spreading. Also useful in fish suction applications.

## TEMP. RANGE

-13°F to 140°F

## CONSTRUCTION

Flexible PVC, rigid PVC helix, smooth bore, smooth O.D.

## NOTE

Not a food-grade hose

## AVAILABLE SIZES

1-1/4, 1-1/2, 2, 2-1/2, 3, 4

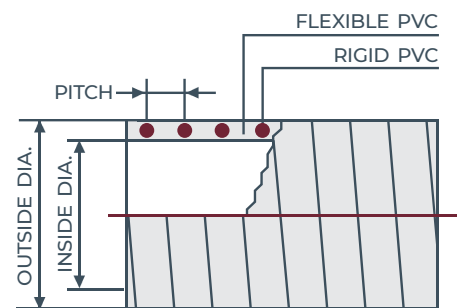
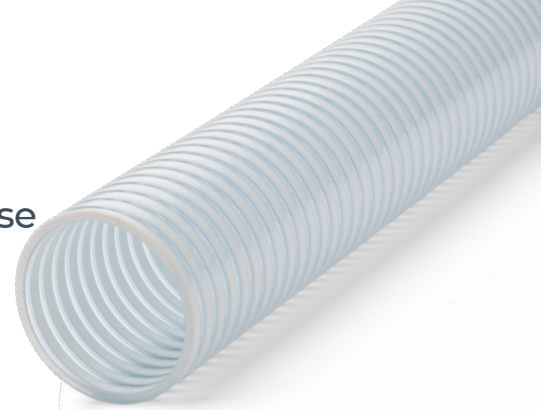

# flexFLO™ U 113 (113UVCLBK)

All weather suction and discharge hose

*An agile solution for diverse agricultural needs. Lightweight and flexible, its blended polyurethane construction enhances abrasion and UV resistance. Ideal for air seeder, fertilizer sprayer, foam markers, irrigation, manure spreading, and fish suction applications.*

## FEATURES

Lightweight and flexible water and suction hose. Improved abrasion and UltraViolet resistance because of the blended polyurethane construction. Clear sidewall permits visual check of material flow. The smooth bore allows for precise flow because no irregularities in the wall can cause interruptions. Smooth bore also promotes drainability.

## APPLICATIONS

All weather water and suction hose with multiple agricultural applications including, air seeder, fertilizer sprayer, foam markers,

irrigation, and manure spreading. Also useful in fish suction applications.

## TEMP. RANGE

-13°F to 140°F

## CONSTRUCTION

Flexible PVC blended with polyurethane, rigid PVC helix, smooth bore, smooth O.D.

## NOTE

Not a food-grade hose

## AVAILABLE SIZES

1, 1-1/4, 1-1/2, 1-3/4, 2, 2-1/2, 3

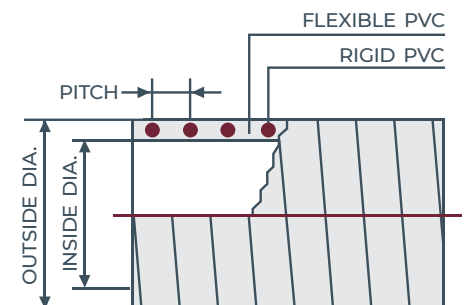



# flexFLO™ 114 (114CL/114GR)

## Lightweight water suction and discharge hose

*An ideal solution for various agricultural applications such as air seeder, fertilizer sprayer, foam markers, irrigation, and manure spreading. Lightweight, flexible, and featuring a clear sidewall for visual inspection, it ensures precise flow and optimal drainability.*

### FEATURES

Lightweight and flexible water and suction hose. Clear sidewall permits visual check of material flow. The smooth bore allows for precise flow because no irregularities in the wall can cause interruptions. Smooth bore also promotes drainability.

### APPLICATIONS

Economical water and suction hose with multiple agricultural applications including, air seeder, fertilizer sprayer, foam markers, irrigation, and manure spreading. Also useful in fish suction applications.

### TEMP. RANGE

-13°F to 140°F

### CONSTRUCTION

Flexible PVC, rigid PVC helix, smooth bore, smooth O.D.

### NOTE

Not a food-grade hose

### AVAILABLE SIZES

1-1/4, 1-1/2, 2, 2-1/2, 3, 4

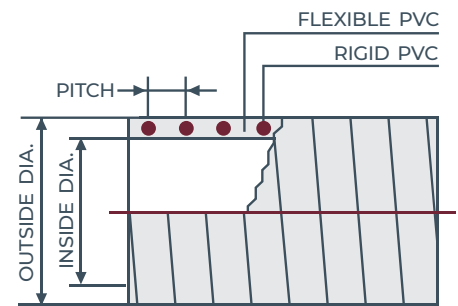

# flexFLO™ 116 Blue (116Blue)

## Cold weather water suction and discharge hose

*An exceptional solution for demanding conditions. Designed to excel in cold weather, this hose ensures reliable water and suction performance with its durable construction.*

### FEATURES

A cold weather suction and discharge hose that will remain flexible in temperatures as cold as -40°F. Clear sidewall permits visual check of material flow. The smooth bore allows for precise flow because no irregularities in the wall can cause interruptions. Smooth bore also promotes drainability.

### APPLICATIONS

Cold weather suction and discharge hose that can be used in agricultural applications on fertilizer sprayers and as an irrigation hose. It can also be used for water pumping in most construction applications.

### TEMP. RANGE

-40°F to 140°F

### CONSTRUCTION

Flexible PVC, rigid PVC helix, smooth bore, smooth O.D.

### NOTE

Not a food-grade hose

### AVAILABLE SIZES

1, 1-1/4, 1-1/2, 2, 2-1/2, 3, 4, 6

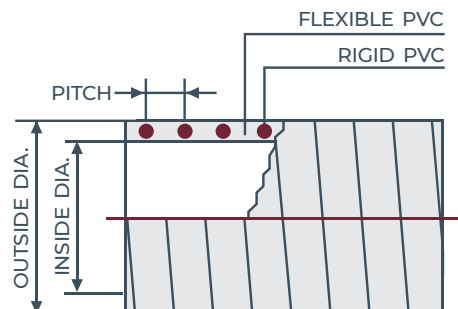

# flexFLO™ SPA (SPA WHITE)

Flexible PVC spa hose

*A versatile solution for spa applications. Flexible, lightweight, and featuring a smooth bore for precise flow and efficient drainability. Compatible with PVC solvent weld fittings only.*

## FEATURES

Flexible and lightweight. The smooth bore allows for precise flow because no irregularities in the wall can cause interruptions. Smooth bore also promotes drainability.

## APPLICATIONS

Water lines, air lines, pump lines

## CONSTRUCTION

Flexible PVC, rigid PVC helix, smooth bore, smooth O.D.

## TEMP. RANGE

-13°F to 158°F

## ACCESSORIES

For use with PVC solvent weld fittings only.

## NOTE

Not a food-grade hose. For use with PVC solvent weld fittings only. Inside diameter is nominal.

Tolerance on outside diameter is + .020, - .005

See usage/storage suggestions and warranty information before use.

## AVAILABLE SIZES

1/2, 3/4, 1, 1-1/4, 1-1/2, 2

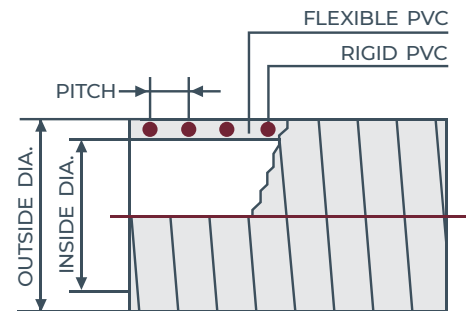
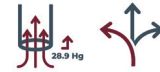

# flexFLO™ lite 100 Blue (100Blue)

Low temp general water suction and discharge hose

*A versatile, lightweight solution for low temperature applications ranging from -40°F to 140°F. Constructed with cold weather PVC, a rigid PVC helix, smooth bore, and corrugated outer diameter, it offers increased flexibility and easy drag in sub-zero conditions. Ideal for general-duty water suction and discharge, with a clear sidewall for visual flow checks.*

## FEATURES

Lightweight with increased flexibility even at sub-zero temperatures. Clear sidewall permits visual check of material flow. External helix provides for easy drag.

## APPLICATIONS

General-duty low temperature water suction and discharge hose with increased flexibility

## TEMP. RANGE

-40°F to 140°F

## CONSTRUCTION

Cold weather PVC, rigid PVC helix, smooth bore, corrugated O.D.

## ACCESSORIES

Banding coil, Powerlock clamp

## NOTE

Not a food-grade hose

## AVAILABLE SIZES

1, 1-1/2, 2, 3, 4, 6, 8

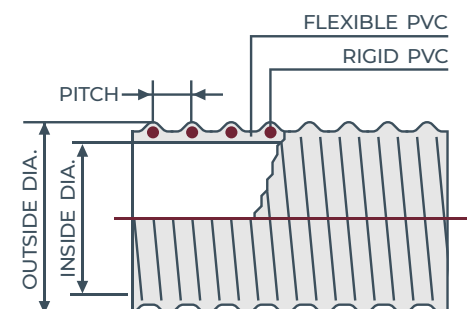
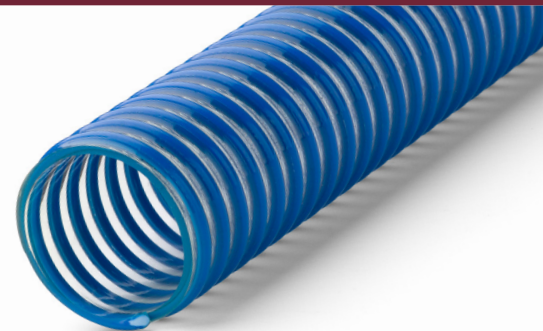

flexFOOD™

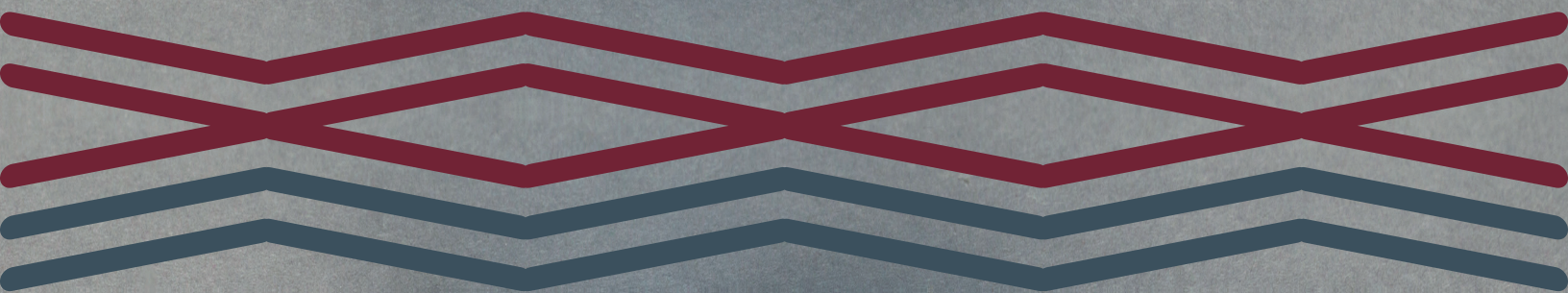
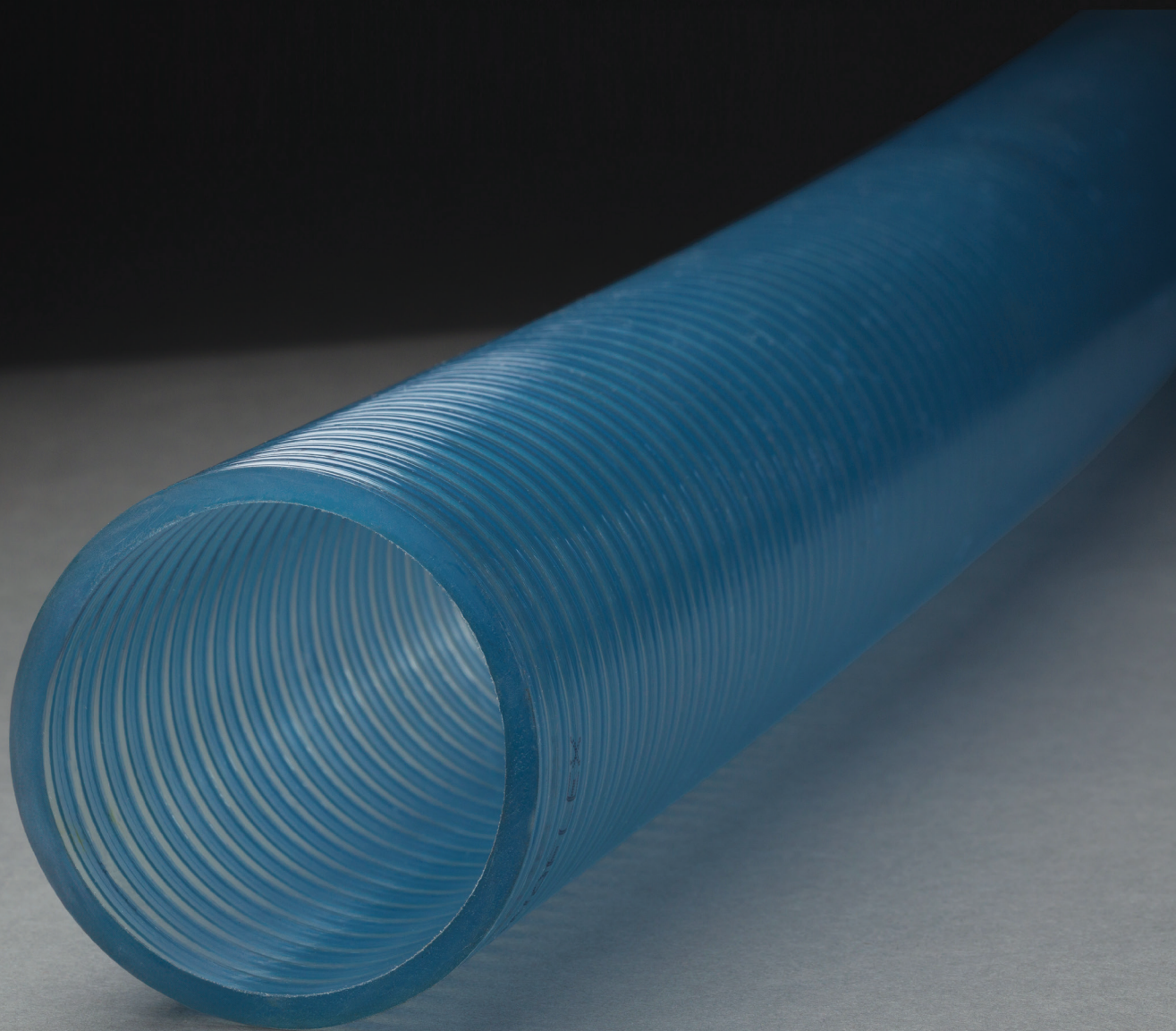

# flexFOOD™ lite 200 (200SFG)

## Food grade suction and discharge hose

*Meticulously crafted to meet FDA and 3-A nontoxic standards. With a clear sidewall for visual inspection and a smooth bore ensuring precise flow and optimal drainability.*

### FEATURES

The food grade hose is constructed in compliance with FDA and 3-A nontoxic specifications. Clear sidewall permits visual check of material flow. The smooth bore allows for precise flow because no irregularities in the wall can cause interruptions. Smooth bore also promotes drainability.

### APPLICATIONS

Food grade suction hose for use in canning, dairy and bottling.

### CONSTRUCTION

Produced entirely of compounds in compliance with FDA and 3-A

non toxic specifications, flexible PVC, rigid PVC helix, smooth bore, corrugated O.D.

### TEMP. RANGE

-13°F to 140°F

### NOTE

Made with NSF51 approved materials

### AVAILABLE SIZES

1, 1-1/4, 1-1/2, 2, 2-1/2, 3, 4

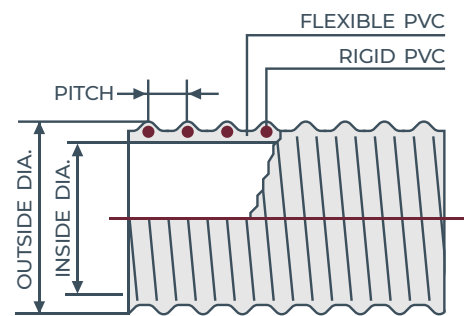
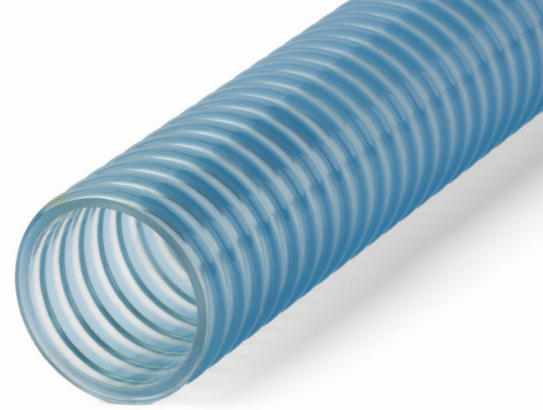

# flexFOOD™ lite 200 ST (ST 200SFG)

## Medium-duty food grade suction and discharge hose

*Crafted to FDA and 3-A nontoxic standards. Ideal for pneumatic conveying of lightweight solids, featuring a clear sidewall, static grounding wire, smooth bore for precise flow, and drainability.*

### FEATURES

The food grade hose is constructed in compliance with FDA and 3-A nontoxic specifications. Clear sidewall permits visual check of material flow. Static grounding wire dissipates static charge when connected to a grounded system.

### APPLICATIONS

Pneumatic conveying of lightweight solids such as powders and plastic pellets. Not to be used for conveying edible food products.

### CONSTRUCTION

Produced entirely of compounds in compliance with FDA and 3-A nontoxic specifications, flexible PVC, rigid PVC helix, multi-strand copper static grounding wire, smooth bore, corrugated O.D.

### TEMP. RANGE

-13°F to 140°F

### NOTE

Made with NSF51 approved materials. If used for abrasive materials, monitor the hose for excessive wear.

### AVAILABLE SIZES

1-1/2, 2, 2-1/2, 3, 4

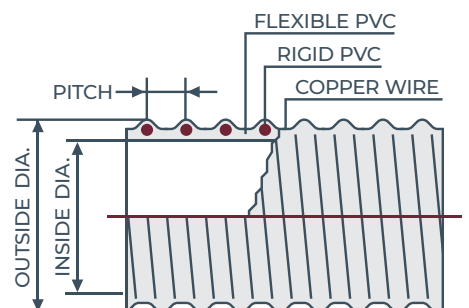

# flexFOOD™ 210 (210HFG)

Heavy-duty food grade suction and discharge hose

*Meticulously crafted to meet FDA and 3-A nontoxic standards. With a clear sidewall for visual inspection and a smooth bore ensuring precise flow and optimal drainability.*

## FEATURES

The food grade hose is constructed in compliance with FDA and 3-A nontoxic specifications. Clear sidewall permits visual check of material flow. The smooth bore allows for precise flow because no irregularities in the wall can cause interruptions. Smooth bore also promotes drainability.

## APPLICATIONS

A food grade suction and discharge hose can be used in food and wine processing applications as well as milk trucks.

## CONSTRUCTION

Produced entirely of compounds in compliance with FDA and 3-A nontoxic specifications, flexible PVC, rigid PVC helix, smooth bore, smooth O.D.

## TEMP. RANGE

-13°F to 140°F

## NOTE

Made with NSF51 approved materials

## AVAILABLE SIZES

3/4, 1, 1-1/4, 1-1/2, 2, 2-1/2, 3, 4

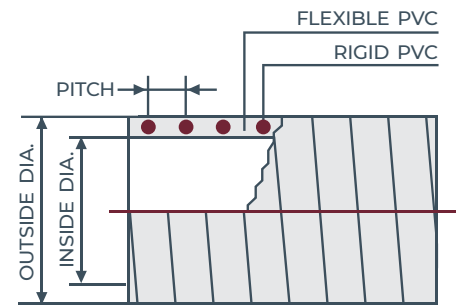
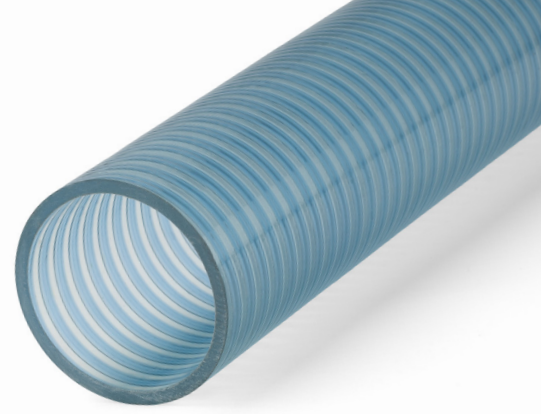

# flexFOOD™ Milk 212 (212 MK)

Heavy-duty food grade suction and discharge hose

*Crafted to FDA and 3-A nontoxic standards. Ideal for milk hauling (tank truck) and pick-up, offering flexibility, visual clarity, precise flow, and optimal drainability.*

## FEATURES

The food grade hose is constructed in compliance with FDA and 3-A nontoxic specifications. Clear sidewall permits visual check of material flow. The smooth bore allows for precise flow because no irregularities in the wall can cause interruptions. Smooth bore also promotes drainability.

## APPLICATIONS

A more flexible version of our KanaFlo FG hose. The KanaFlo MK hose is designed specifically for milk hauling (tank truck) and pick-up.

## CONSTRUCTION

Produced entirely of compounds in compliance with FDA and 3-A nontoxic specifications, flexible PVC, rigid PVC helix, smooth bore, smooth O.D.

## TEMP. RANGE

-13°F to 140°F

## NOTE

Made with NSF51 approved materials

## AVAILABLE SIZES

1-1/2, 2, 2-1/2, 3

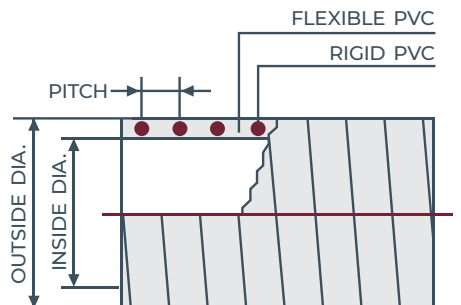
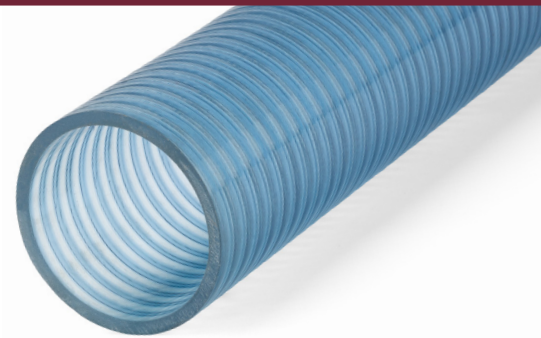

flexLINE™

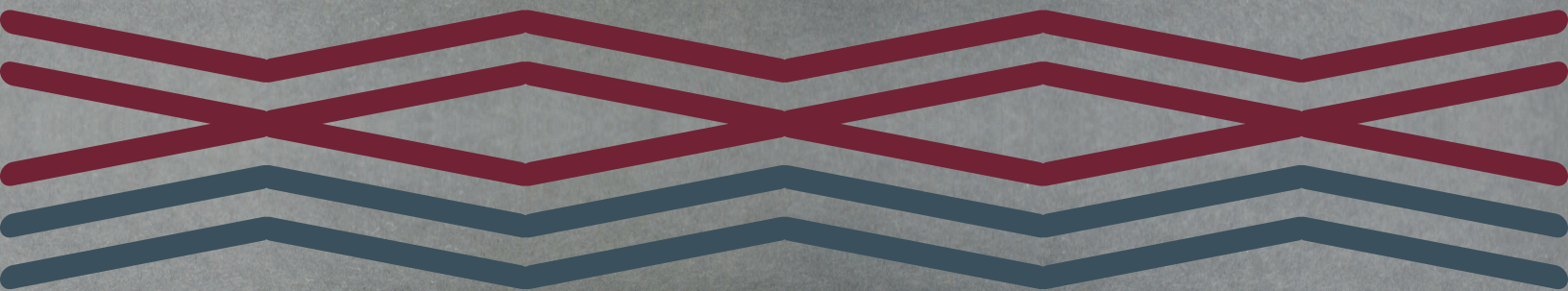
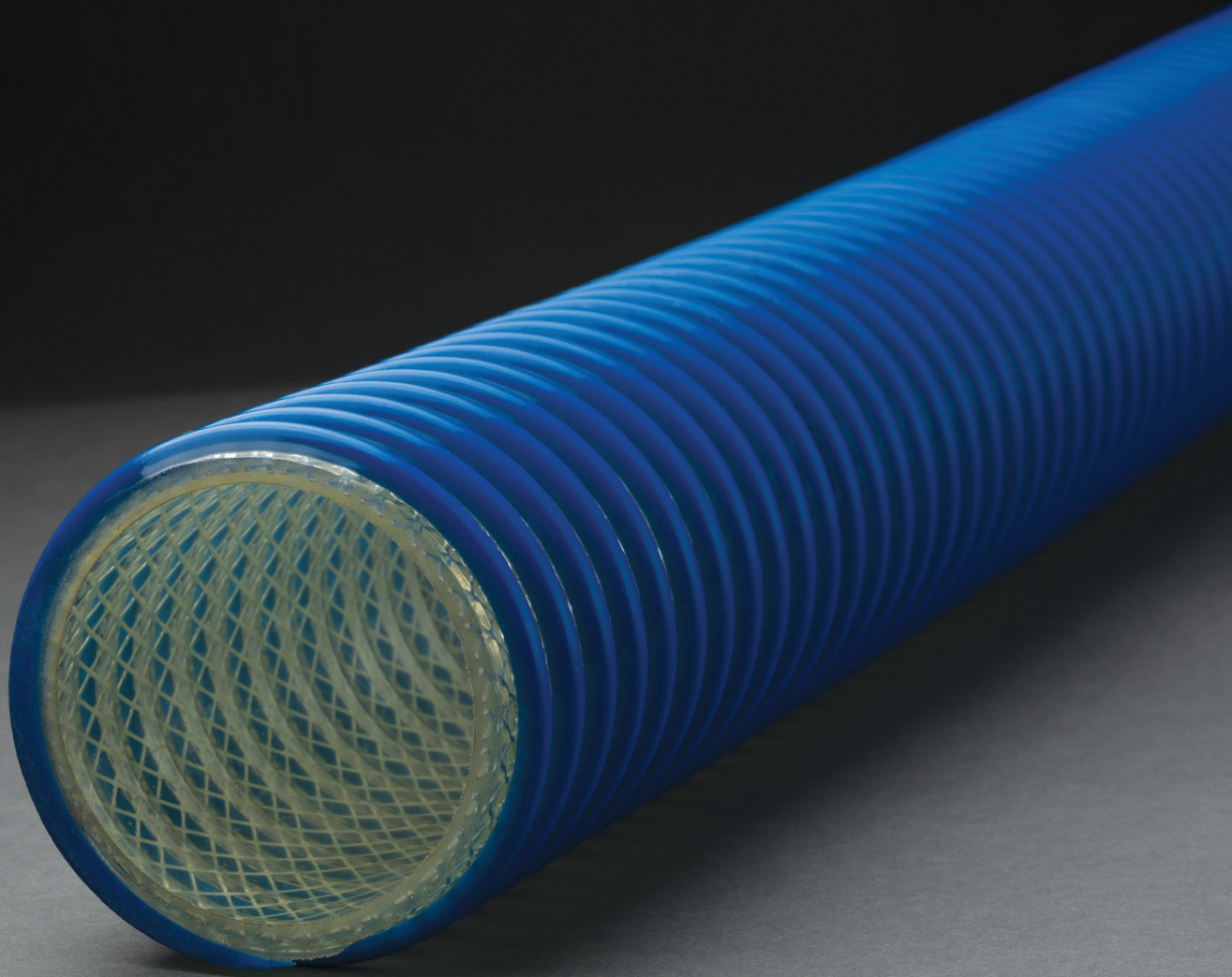

# flexLINE™ CW (KLCWB)

Reinforced cold weather suction and discharge hose

*A versatile solution designed for extreme cold conditions. Lightweight with cold weather PVC and synthetic braiding for flexibility and durability. Ideal for liquid fertilizer spreading in agriculture and fish suction and ice slinging in the fishing industry.*

## FEATURES

Lightweight and flexible hose constructed with cold weather PVC, making it perfect for the most demanding cold conditions. The synthetic braiding gives the hose increased flexibility and durability.

## APPLICATIONS

The reinforced cold weather suction and discharge hose can be used in the spreading of liquid fertilizer in agricultural applications. It can also be used in the fishing industry for both fish suction and ice slinging.

## TEMP. RANGE

-40°F to 140°F

## CONSTRUCTION

Flexible cold weather PVC, rigid PVC helix, synthetic braiding, smooth bore, corrugated O.D.

## ACCESSORIES

Banding coil, Powerlock clamp

## NOTE

Not a food-grade hose. Banding coil must be used for all sizes.

## AVAILABLE SIZES

1-1/2, 2, 3, 4, 6, 8, 10

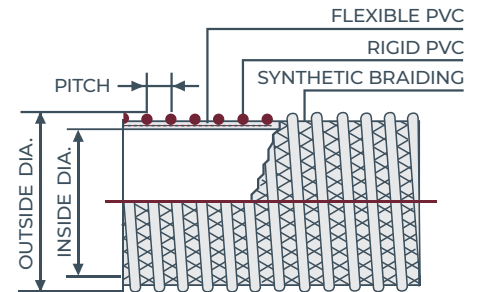

# flexLINE™ Blue (KLCWB)

Reinforced cold weather suction and discharge hose

*A versatile solution for combined vacuum, higher working pressures, and increased flexibility. Lightweight and flexible with an external helix for easy drag, it's ideal for colder environments and liquid fertilizer applications.*

## FEATURES

Lightweight and flexible hose constructed with cold weather PVC, making it perfect for the most demanding cold conditions. The synthetic braiding gives the hose increased flexibility and durability.

## APPLICATIONS

The reinforced cold weather suction and discharge hose can be used in the spreading of liquid fertilizer in agricultural applications. It can also be used in the fishing industry for both fish suction and ice slinging.

## TEMP. RANGE

-40°F to 140°F

## CONSTRUCTION

Flexible cold weather PVC, rigid PVC helix, synthetic braiding, smooth bore, corrugated O.D.

## ACCESSORIES

Banding coil, Powerlock clamp

## NOTE

Not a food-grade hose. Banding coil must be used for all sizes.

## AVAILABLE SIZES

1-1/2, 2, 3, 4, 6, 8, 10, 12

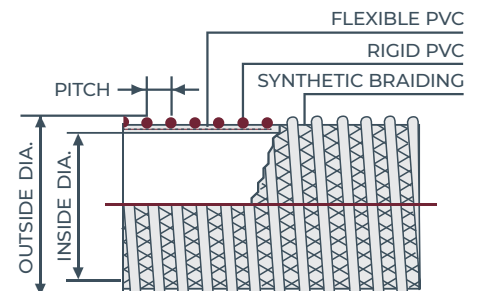
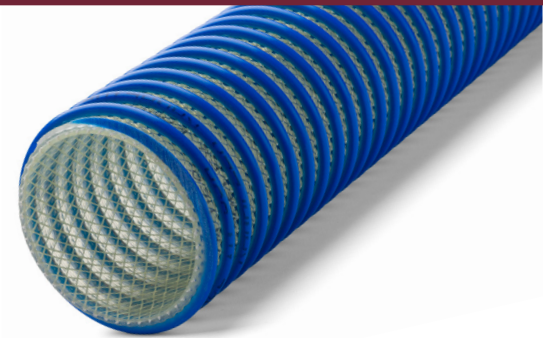

# flexLINE™ SR (KLSR)

Water suction/discharge hose for heavy-duty applications requiring combined vacuum and higher working pressures

*A lightweight and flexible solution with easy drag. Ideal for fish suction, rental/construction pumping, and agricultural irrigation, featuring a clear sidewall for visual inspection and a smooth bore for precise flow and enhanced drainability.*

## FEATURES

Lightweight and flexible with an external helix that provides for easy drag. Clear sidewall permits visual check of material flow. The smooth bore allows for precise flow because no irregularities in the wall can cause interruptions. Smooth bore also promotes drainability.

## APPLICATIONS

Heavy duty suction and discharge hose for use in fish suction, rental/construction pumping, and agricultural irrigation.

## TEMP. RANGE

-13°F to 140°F

## CONSTRUCTION

Flexible PVC, rigid PVC helix, synthetic braiding, smooth bore, corrugated O.D.

## ACCESSORIES

Banding coil, Powerlock clamp

## NOTE

Not a food-grade hose. Banding coil must be used for 1-1/2", 2", 3", 4", 5" and 6" sizes.

## AVAILABLE SIZES

1-1/2, 2, 3, 4, 5, 6, 8, 10, 12

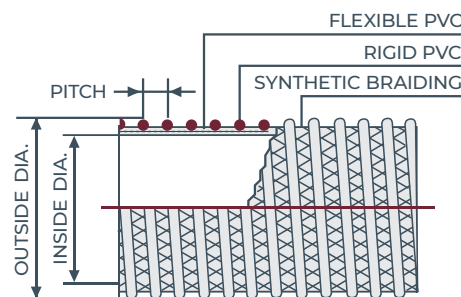
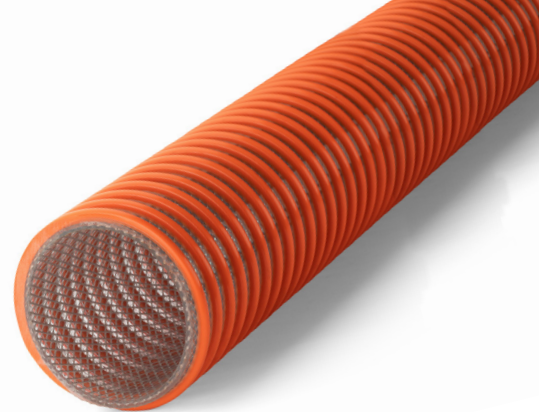

# flexLINE™ U Food Grade (STKLUG)

Heavy-duty reinforced polyurethane food-grade suction and discharge hose

*An ideal for sub-zero conditions. Featuring a clear food-grade polyurethane tube, static grounding, and dissipative materials, it ensures safe and efficient transfer of abrasive/food grade materials.*

## FEATURES

Lightweight and flexible in sub-zero temperatures. Clear food-grade polyurethane tube provides increased abrasion resistance, permits visual check of material flow, prevents material build up and provides quiet operation.

## APPLICATIONS

Transfer of abrasive/food grade materials - bulk unloading of railcars and trucks. Fish suction.

## CONSTRUCTION

Flexible static dissipative polyurethane liner and PVC, rigid PVC helix, synthetic braiding, no

direction required, smooth bore, PVC corrugated O.D. with copper grounding wire. Produced entirely of compounds in compliance with FDA and 3-A non-toxic specifications.

## TEMP. RANGE

-33°F to 140°F

## NOTE

Made with NSF51 approved materials

## ACCESSORIES

Banding coil or Powerlock Clamp must be used for all sizes.

## AVAILABLE SIZES

3, 4, 5, 6

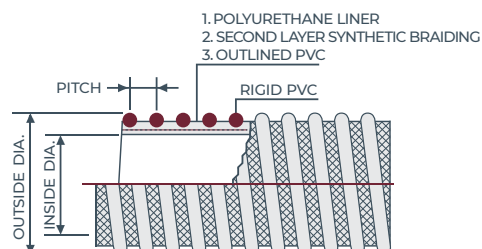
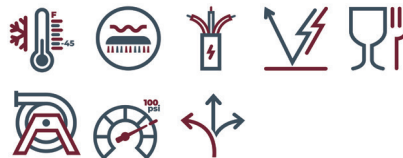
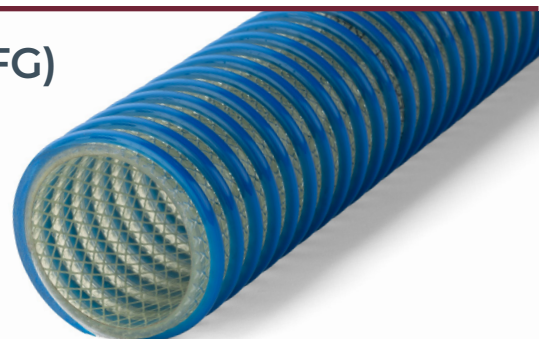



# flexLINE™ Food Grade (KLFW)

Heavy-duty reinforced food grade suction and discharge hose

*A versatile solution for bottling, wine making, canning, dairy, brewing, and liquid foods. Lightweight, flexible, and constructed with FDA and 3-A compliant materials.*

## FEATURES

Lightweight and flexible. Clear food-grade flexible PVC with synthetic braiding provides increased abrasion resistance, permits visual check of material flow, and prevents material build up. External helix provides for easy drag. Rated for both suction and discharge.

## APPLICATIONS

Heavy-duty reinforced food grade suction and discharge hose for bottling, wine making, canning, dairy, brewing and liquid foods

## CONSTRUCTION

Produced entirely of compounds in compliance with FDA and 3-A

nontoxic specifications, flexible PVC, rigid PVC helix, synthetic braiding, smooth bore, corrugated O.D.

## TEMP. RANGE

-13°F to 140°F

## ACCESSORIES

Banding coil, Powerlock clamp

## NOTE

Made with NSF51 approved materials. Banding coil must be used for all sizes. 5" and 6" sizes are not a stock items. Consult factory for availability.

## AVAILABLE SIZES

1-1/2, 2, 3, 4, 5, 6

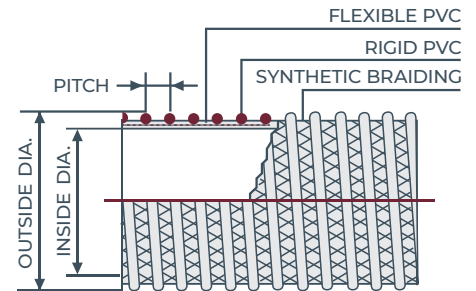

|||| flexVAC™

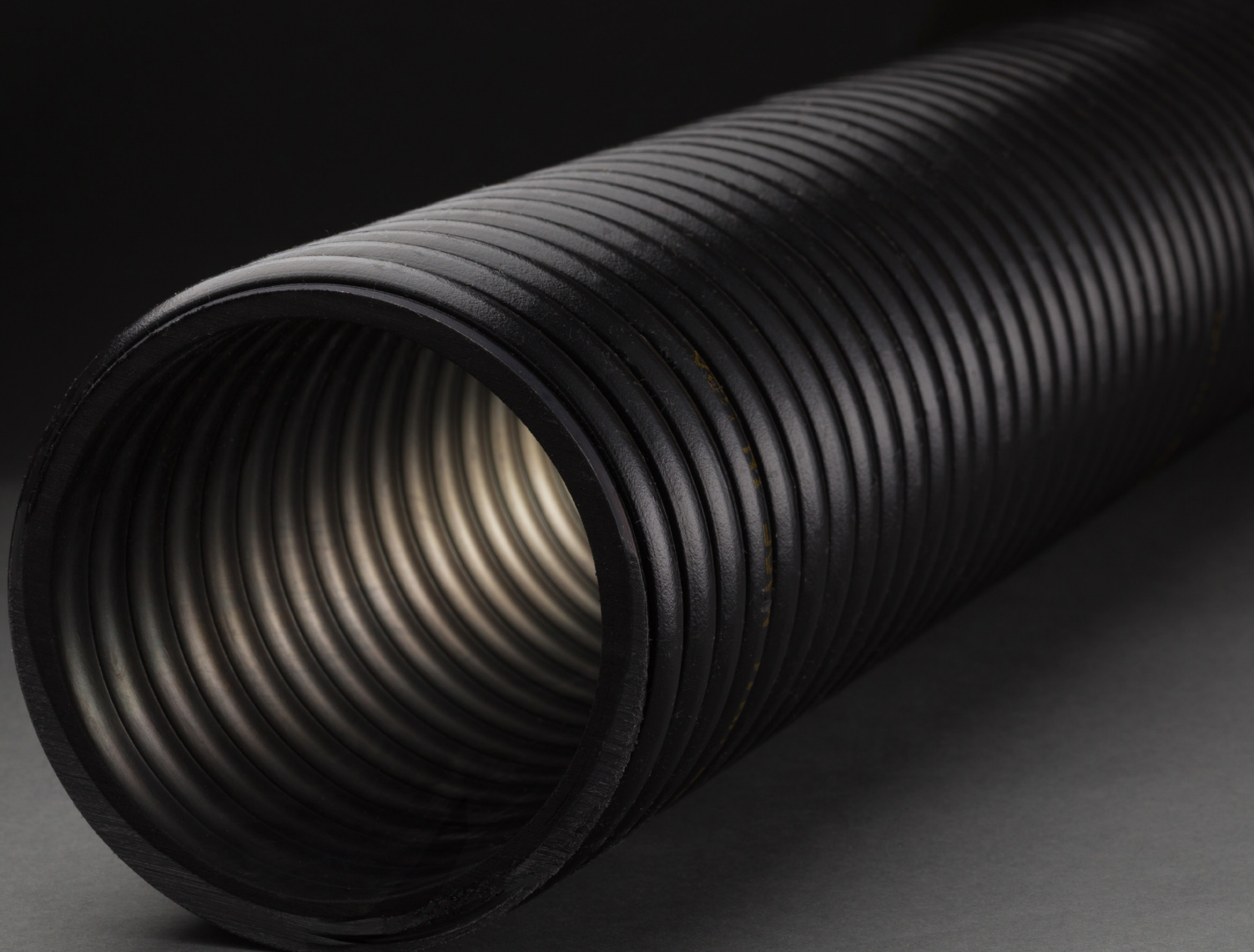

# flexVAC™ lite 180 AR (180BL)

Lightweight abrasion resistant blower and suction hose

*A versatile solution for suction and light blowing of lightweight abrasives. Its SBR rubber blend with static carbon black ensures exceptional abrasion resistance and static dissipation. Ideal for materials like rockwool, fiberglass, sawdust, grain, insulation, and cement dust.*

## FEATURES

The lightweight and flexible SBR rubber hose blended with static carbon black makes it extremely abrasion resistant. Static dissipating with no grounding wire. The smooth bore allows for precise flow because no irregularities in the wall can cause interruptions.

## APPLICATIONS

Designed for suction and light blowing of lightweight abrasives such as rockwool, fiberglass, sawdust, grain, insulation and cement dust.

## TEMP. RANGE

-40°F to 140°F

## CONSTRUCTION

SBR rubber blended with static carbon black, rigid PVC helix, smooth bore, corrugated O.D.

## AVAILABLE SIZES

2-1/2, 3, 4, 5, 6, 7, 8

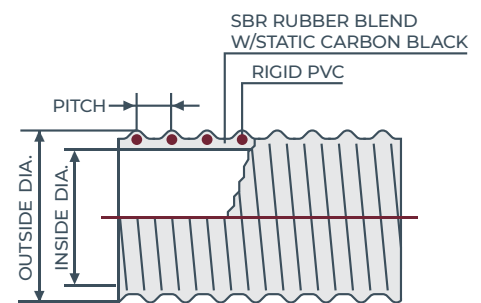

# flexVAC™ lite 180 MVAR (180MV)

Medium-duty abrasion resistant suction and discharge hose

*A versatile solution for various applications. Lightweight and flexible, the SBR rubber hose with static carbon black ensures exceptional abrasion resistance and static dissipation. Perfect for grain and roof vacuums, featuring an external helix for easy drag and a smooth bore for precise flow.*

## FEATURES

The lightweight and flexible SBR rubber hose blended with static carbon black makes it extremely abrasion resistant. Static dissipating with no grounding wire. External helix provides easy drag. The smooth bore allows for precise flow because no irregularities in the wall can cause interruptions.

## APPLICATIONS

Designed for numerous applications such as grain and roof vacuums.

## TEMP. RANGE

-40°F to 140°F

## CONSTRUCTION

SBR rubber with carbon black, rigid PVC helix, smooth bore, corrugated O.D.

## AVAILABLE SIZES

5, 6

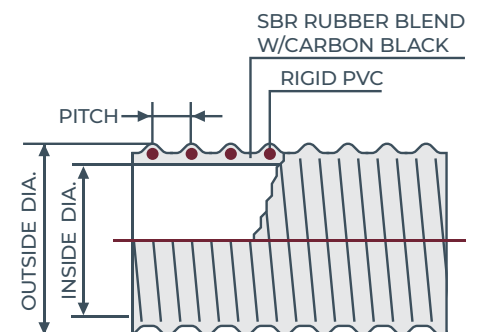

# flexVAC™ 180 AR (180AR)

Heavy-duty abrasion resistant suction and discharge hose

*A robust solution for demanding applications. Lightweight and flexible, the SBR rubber hose with static carbon black ensures exceptional abrasion resistance, static dissipation, and precise flow. Ideal for vacuum trucks handling crushed rock, sand, pea gravel, cement powder, dry fertilizer, iron ore, and grains.*

## FEATURES

The lightweight and flexible SBR rubber hose blended with static carbon black makes it extremely abrasion resistant. Static dissipating with no grounding wire. The smooth bore allows for precise flow because no irregularities in the wall can cause interruptions. Smooth bore also promotes drainability.

## APPLICATIONS

Heavy-duty abrasion resistant suction hose for vacuum trucks or handling abrasives such as crushed rock, sand, pea gravel, cement powder, dry fertilizer, iron ore and grains

## TEMP. RANGE

-40°F to 140°F

## CONSTRUCTION

SBR rubber blended with static carbon black, rigid PVC helix, smooth bore, corrugated O.D.

## NOTE

This hose was not designed for bulk handling such as unloading of rail cars.

## AVAILABLE SIZES

1-1/4, 1-1/2, 2, 2-1/2, 3, 3-1/2, 4, 5, 6, 7, 8, 10, 12

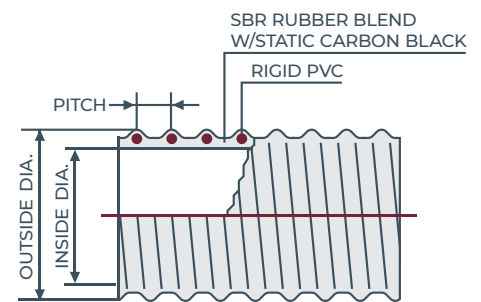

# flexVAC™ 180 STAR (180STAR)

Heavy-duty abrasion resistant suction and discharge hose

*A robust solution for demanding applications. Lightweight and flexible, the SBR rubber hose with static carbon black and a grounding wire ensures maximum static resistance. Ideal for vacuum trucks handling abrasives like crushed rock, sand, pea gravel, cement powder, dry fertilizer, iron ore, and grains.*

## FEATURES

The lightweight and flexible SBR rubber hose blended with static carbon black and a static grounding wire provide maximum static resistance when connected to a grounded system. The smooth bore allows for precise flow because no irregularities in the wall can cause interruptions. External helix provides easy drag.

## APPLICATIONS

Heavy-duty abrasion resistant suction hose for vacuum trucks or handling abrasives such as crushed rock, sand, pea gravel, cement powder, dry fertilizer, iron ore and grains.

## TEMP. RANGE

-40°F to 140°F

## CONSTRUCTION

SBR rubber blended with static carbon black, rigid PVC helix, smooth bore, with copper wire, corrugated O.D.

## NOTE

This hose was not designed for bulk handling such as unloading of rail cars.

## AVAILABLE SIZES

1-1/2, 2, 3, 4, 6

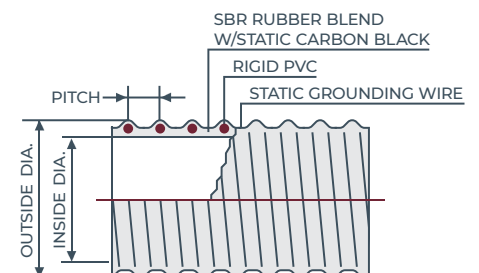
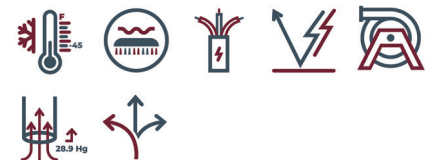

# flexVAC™ 180 HR (180HR)

High temperature abrasion resistant suction hose

*An ideal solution for heavy-duty suction applications in high-temperature and abrasive environments. Lightweight, flexible, and designed to withstand temperatures up to 220°F, it ensures efficient material handling of fly ash, crushed rock, sand, pea gravel, or cement powder.*

## FEATURES

Lightweight and flexible suction hose designed to sustain temperatures up to 220°F. Integral wire helix can be grounded. External helix provides easy drag. The smooth bore allows for precise flow because no irregularities in the wall can cause interruptions.

## APPLICATIONS

Heavy-duty suction applications where high temperature and abrasion are factors such as vacuum trucks or the handling of fly ash, crushed rock, sand, pea gravel or cement powder

## CONSTRUCTION

EPDM rubber, polyethylene helix, metal helical wire, smooth bore, corrugated O.D.

## TEMP. RANGE

-40°F to 220°F

## AVAILABLE SIZES

4, 6, 8

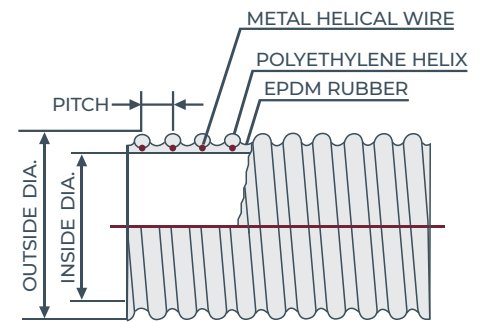
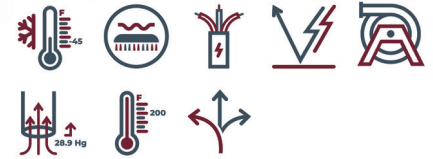

# flexVAC™ U Boom ST (STKB)

Heavy-duty abrasion resistant wet and dry material handling hose

*A reliable choice for diverse applications. Lightweight and flexible in sub-zero temperatures, featuring an abrasive-resistant polyurethane tube for extended lifetime and quiet operation. Ideal for hydro-vac trucks, vacuum trucks, general construction, and wet and dry applications, with a full vacuum rating.*

## FEATURES

Lightweight and flexible in sub-zero temperatures. Abrasive resistant polyurethane tube provides increased lifetime, prevents material build-up and provides quiet operation.

## APPLICATIONS

Hydro-vac truck, vacuum truck, general construction use, wet and dry full vacuum rated.

## CONSTRUCTION

Flexible high abrasion polyurethane liner, rigid PVC helix, no direction required, smooth bore, extra UV

inhabitant PVC corrugated O.D. with static dissipating materials and grounding wire.

## TEMP. RANGE

-33°F to 140°F

## ACCESSORIES

Banding coil or Powerlock Clamp (must be used for all sizes)

## NOTE

Not a food-grade hose

## AVAILABLE SIZES

4, 6, 8

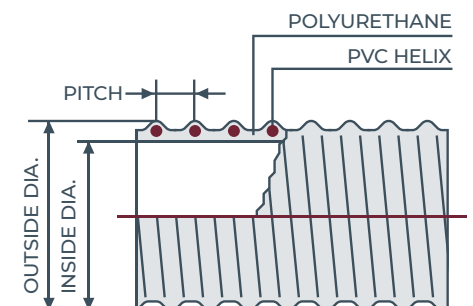
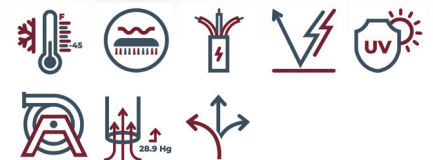
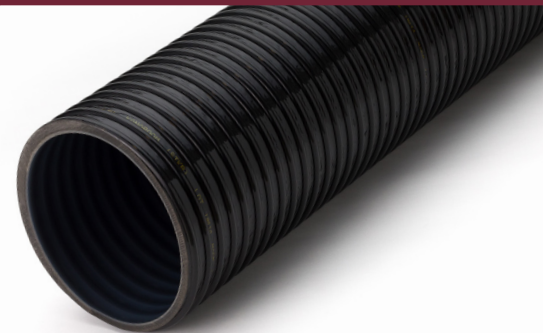

# flexVAC™ lite U Boom ST (STKB LITE)

Medium-duty wet & dry material remote hose with grounding wire

*Ideal for diverse applications. Lightweight, flexible, and abrasion-resistant, with a static copper wire for dissipating charges. Suitable for hydro-vac trucks, vacuum trucks, general construction with rock, gravel, sand, and crushed concrete.*

## FEATURES

Lightweight and flexible in sub-zero temperatures. Abrasive resistant polyurethane tube provides increased lifetime, prevents material build-up and provides quiet operation.

## APPLICATIONS

Hydro-vac truck, vacuum truck, general construction use, such as rock, gravel, sand and crushed concrete. Industrial vac equipment, roof vac, dry fertilizer and petcoke.

## CONSTRUCTION

Flexible abrasion polyurethane liner, rigid PVC helix, smooth bore, PVC

corrugated O.D. with static dissipating materials and grounding wire.

## TEMP. RANGE

-40°F to 140°F

## ACCESSORIES

Banding coil or Powerlock Clamp (must be used for all sizes)

## NOTE

Not a food-grade hose

## AVAILABLE SIZES

3, 4, 5, 6

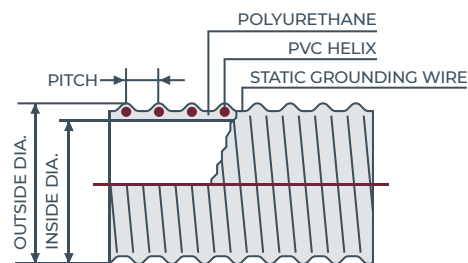
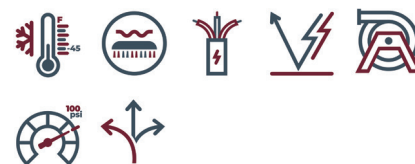

# flexVAC™ Max (KPAT)

Heavy-duty high pressure suction and discharge hose

*Crafted for demanding applications like slurry in micro-tunneling and directional boring. Its SBR rubber blend with static carbon black ensures exceptional abrasion resistance and static dissipation.*

## FEATURES

The lightweight and flexible SBR rubber hose blended with static carbon black makes it extremely abrasion resistant. Static dissipating with no grounding wire. The synthetic braiding gives the hose increased flexibility and durability. External helix provides easy drag. The smooth bore allows for precise flow because no irregularities in the wall can cause interruptions.

## APPLICATIONS

Abrasion resistant suction and discharge hose designed for demanding applications such as slurry in micro-tunneling applications and directional boring

## TEMP. RANGE

Range: -30°F to 140°F

## CONSTRUCTION

SBR rubber blended with static carbon black, rigid PVC helix, smooth bore, synthetic braid, corrugated O.D.

## NOTE

6" size is not a stock item. Consult factory for availability.

## AVAILABLE SIZES

4, 6

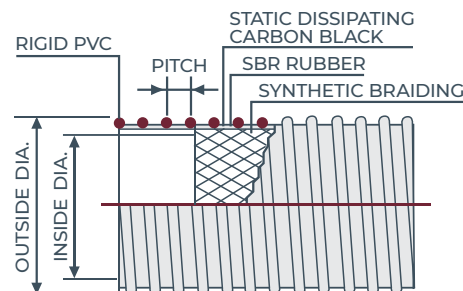

flexCHEM™

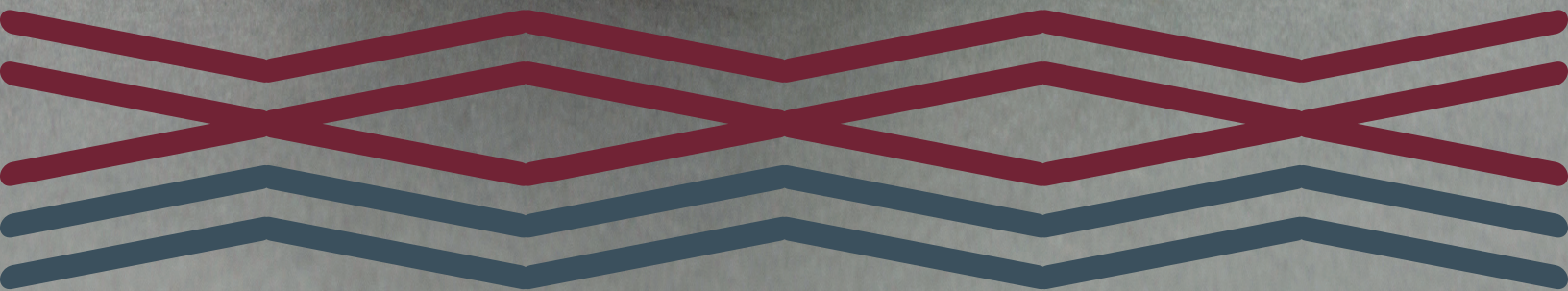
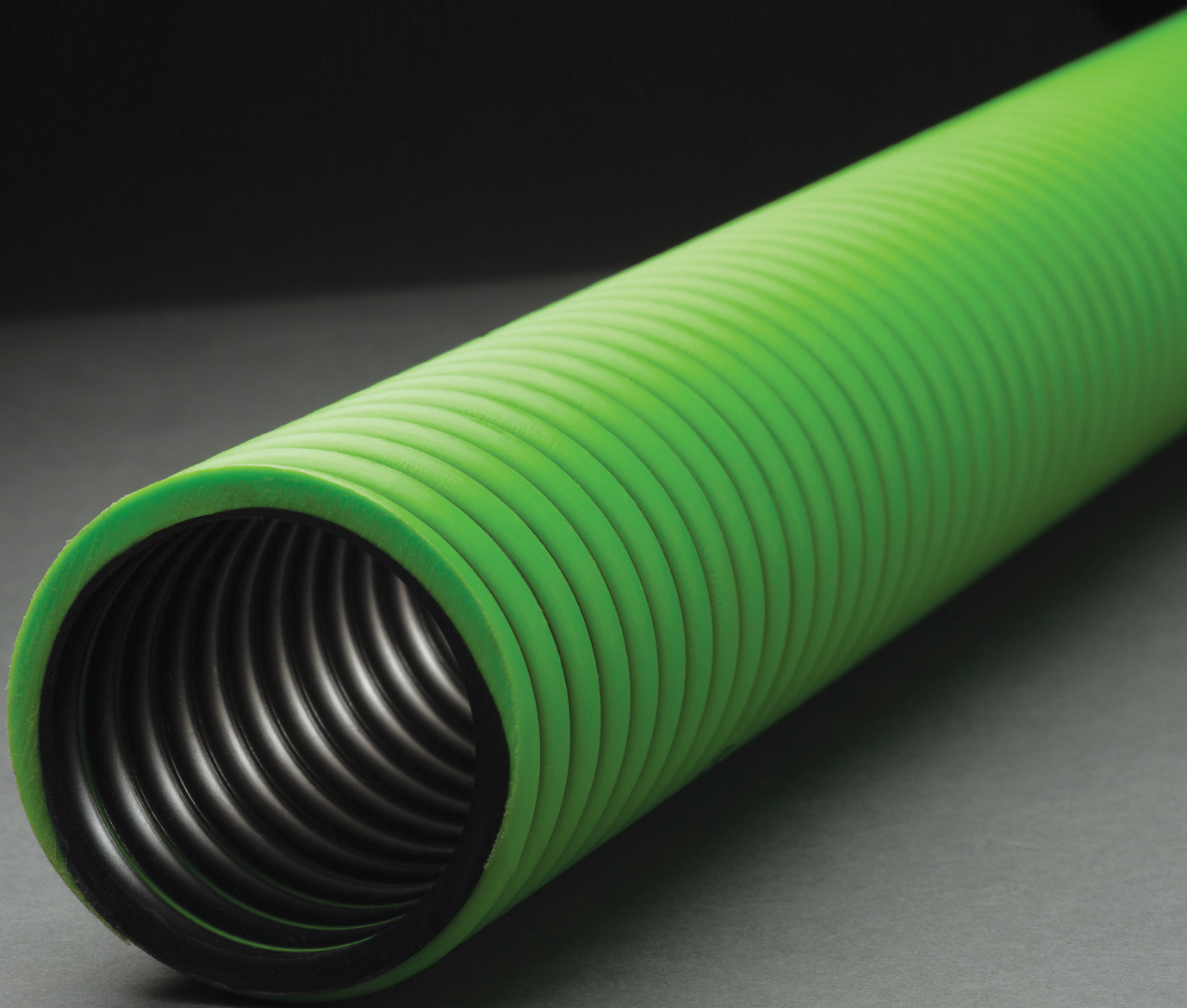

# flexCHEM™ 220 (ST 220RS)

Heavy-duty abrasion resistant chemical suction and discharge hose

*An ideal solution for demanding environments. Lightweight and flexible, its SBR rubber blend with static carbon black ensures abrasion resistance and static dissipation. Perfect for construction dewatering, liquid waste, cesspool cleaning, septic handling, agricultural applications, and marine use. The smooth bore allows for precise flow without interruptions.*

## FEATURES

The lightweight and flexible SBR rubber hose blended with static carbon black makes it abrasion resistant. Static dissipating with no grounding wire. The smooth bore allows for precise flow because no irregularities in the wall can cause interruptions.

## APPLICATIONS

Heavy-duty chemical liquid suction hose for use in construction dewatering, liquid waste, cesspool cleaning, septic handling, agricultural applications and marine use.

## TEMP. RANGE

-40°F to 140°F

## CONSTRUCTION

SBR rubber with static carbon black, rigid PVC helix, smooth bore, smooth O.D.

## AVAILABLE SIZES

1-1/2, 2, 2-1/2, 3, 4, 6

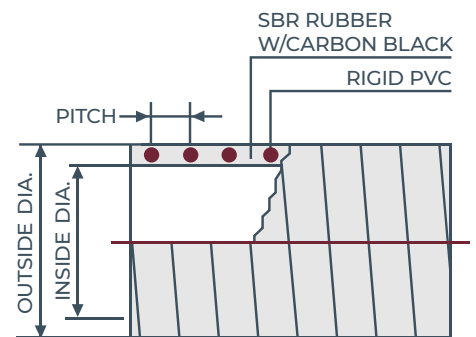
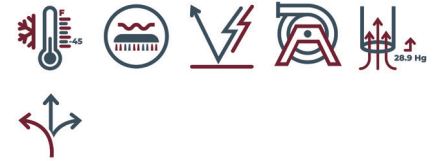

# flexCHEM™ 300 (300GR/EPDM)

All purpose chemical suction and discharge hose

*A versatile solution for challenging environments. Lightweight and flexible, resistant to most agricultural chemicals, with an external helix for easy drag. Ideal for construction dewatering, liquid waste, cesspool cleaning, septic handling, agricultural applications, and marine use. The smooth bore ensures precise flow.*

## FEATURES

Lightweight and flexible, this hose is resistant to most agricultural chemicals. External helix provides for easy drag. The smooth bore allows for precise flow because no irregularities in the wall can cause interruptions.

## APPLICATIONS

Heavy-duty liquid suction hose for use in construction dewatering, liquid waste, cesspool cleaning, septic handling, agricultural applications and marine use.

## TEMP. RANGE

-40°F to 140°F

## CONSTRUCTION

EPDM rubber, polyethylene helix, smooth bore, corrugated O.D.

## NOTE

Hose available with red, blue, yellow, and black helix with 500 ft. minimum order.

## AVAILABLE SIZES

1, 1-1/4, 1-1/2, 2, 2-1/2, 3, 4, 6

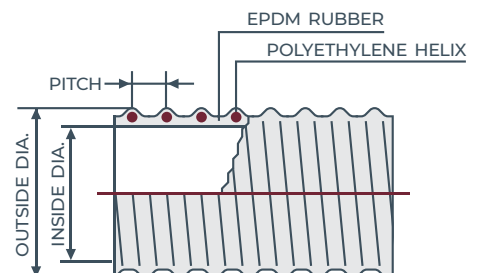



# flexCHEM™ 390 (390 SD)

Heavy-duty reinforced chemical suction and discharge hose

*Combining flexibility and durability. With synthetic braiding for increased flexibility and abrasion resistance, it's rated for both suction and discharge. Resistant to agricultural chemicals, ideal for construction applications, and suitable for liquids such as agricultural chemicals, liquid fertilizers, and dewatering.*

## FEATURES

The lightweight hose comes with synthetic braiding that provides increased flexibility and abrasion resistance. Rated for both suction and discharge. External helix provides for easy drag. Resistant to agricultural chemicals and durable in construction applications. The smooth bore allows for precise flow because no irregularities in the wall can cause interruptions.

## APPLICATIONS

Suction and discharge of liquids in the construction, and agricultural industries such as agricultural

chemicals, liquid fertilizers, and dewatering

## TEMP. RANGE

-40°F to 140°F

## CONSTRUCTION

EPDM rubber, polyethylene helix, synthetic braiding, smooth bore, corrugated O.D.

## ACCESSORIES

Banding coil, Powerlock clamp

## AVAILABLE SIZES

1-1/4, 1-1/2, 2, 3

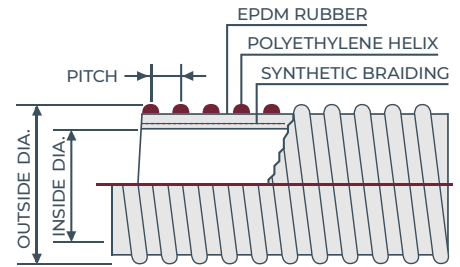

|||| flexVAPOR™

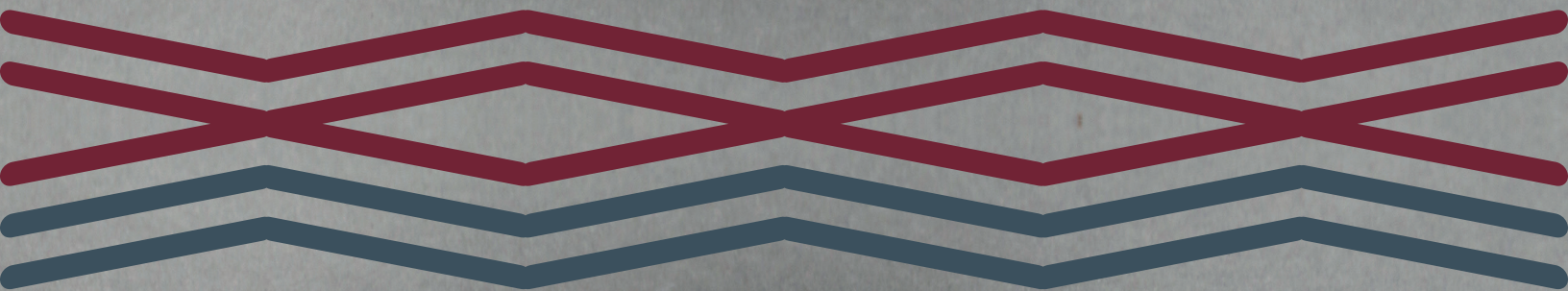
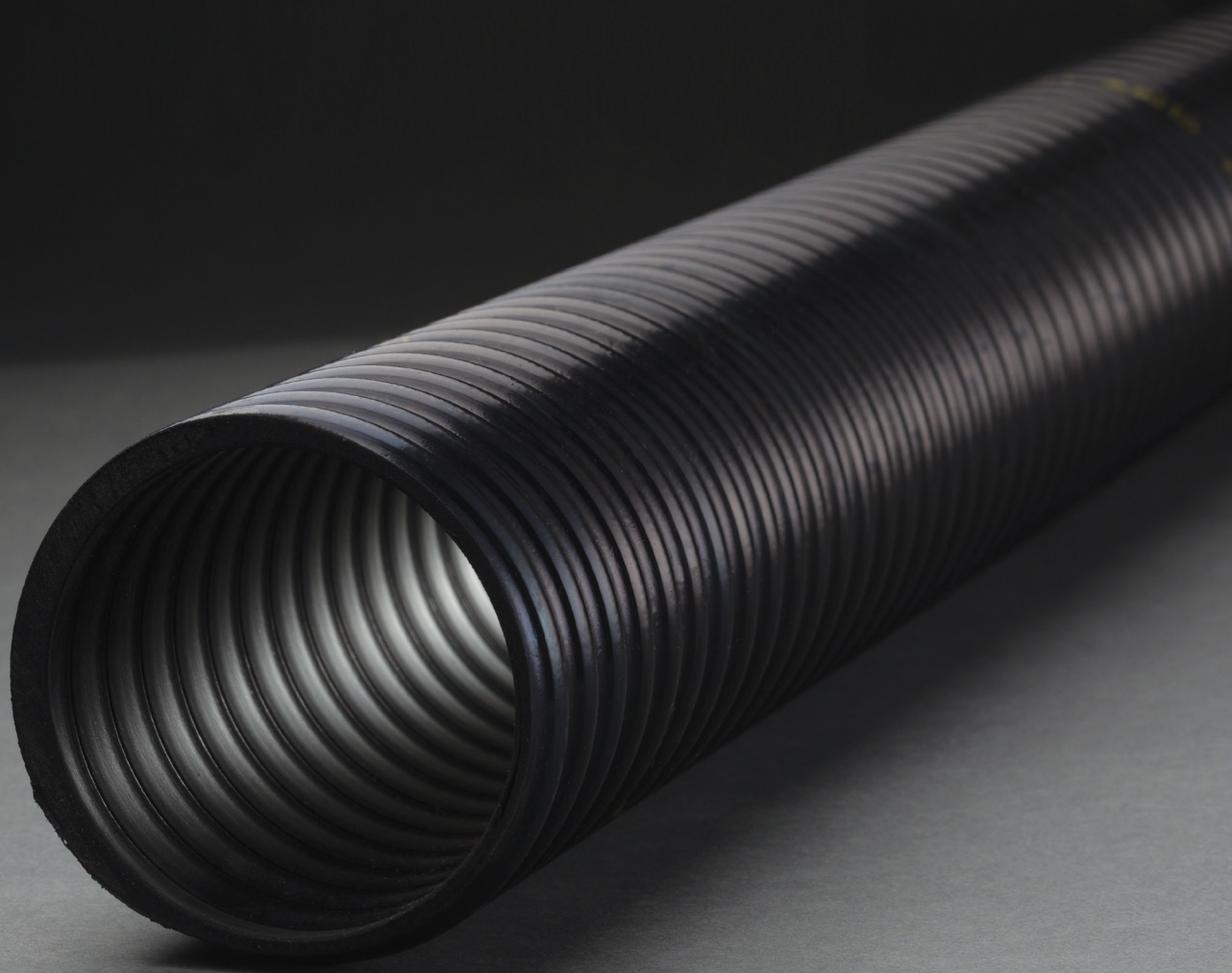

# flexVAPOR™ lite U 101 (101PS UVOR)

General vapor, water suction and discharge hose

*An adaptable solution for diverse applications. Constructed with flexible PVC, it ensures durability with solid wall construction and UV inhibitors. Ideal for methane gas recovery at landfills, connecting rigid pipes, and repairing broken lines.*

## FEATURES

Lightweight and flexible hose constructed with flexible PVC. The solid wall construction and extra UV inhibitors provide increased durability. External helix provides for easy drag. Rated for both suction and discharge. The smooth bore allows for precise flow because no irregularities in the wall can cause interruptions. Smooth bore also promotes drainability.

## APPLICATIONS

General vapor hose with solid wall construction and UV inhibitors make it perfect for methane gas recovery

at landfills. It can also be used in the connection of rigid pipes of the same size, and the repair of broken rigid lines.

## CONSTRUCTION

Flexible PVC, rigid PVC helix, smooth bore, corrugated O.D.

## TEMP. RANGE

-13°F to 140°F

## NOTE

Not a food-grade hose

## AVAILABLE SIZES

2.375, 3-1/2, 4-1/2

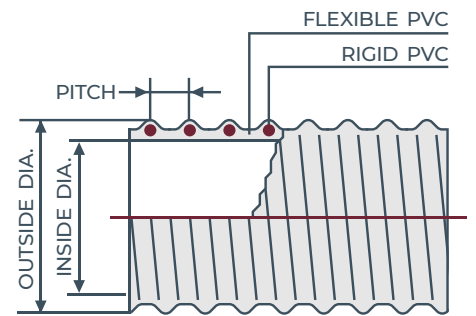

# flexVAPOR™ 120 ST (ST120 VP)

Gasoline vapor recovery hose

*A specialized solution for vapor recovery. Featuring a nitrile rubber static dissipating tube, grounding wire, and smooth bore for precise flow. External helix ensures easy drag.*

## FEATURES

Nitrile rubber static dissipating tube and static grounding wire provide maximum static resistance when connected to a grounded system. The smooth bore allows for precise flow because no irregularities in the wall can cause interruptions. External helix provides easy drag.

## APPLICATIONS

Gasoline vapor recovery hose only

## CONSTRUCTION

Nitrile rubber, rigid PVC helix, smooth bore, corrugated O.D., static grounding wire

## TEMP. RANGE

-40°F to 140°F

## NOTE

Static wire must be properly imbedded during fitting installation and tested to assure proper static grounding of hose to a grounded system.

## AVAILABLE SIZES

2, 3, 4

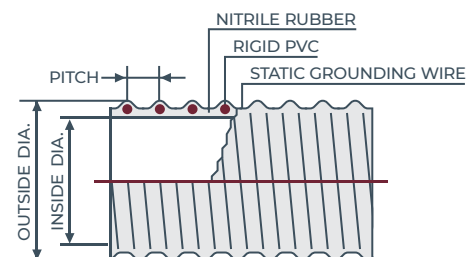
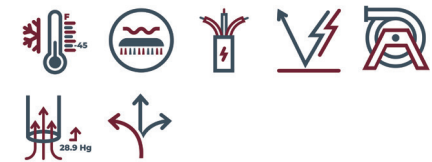

# flexVAPOR™ U 120 ST (ST120 UACVR)

All purpose tank truck and terminal vapor recovery hose

*An adaptable solution for various fuels. Lightweight and flexible, constructed with polyurethane for use with gasoline blends, biodiesel, ethanol, kerosene, diesel, and ASTM fuel oils. Featuring a static dissipating tube and multi-strand copper static wire for ultimate protection against static discharge.*

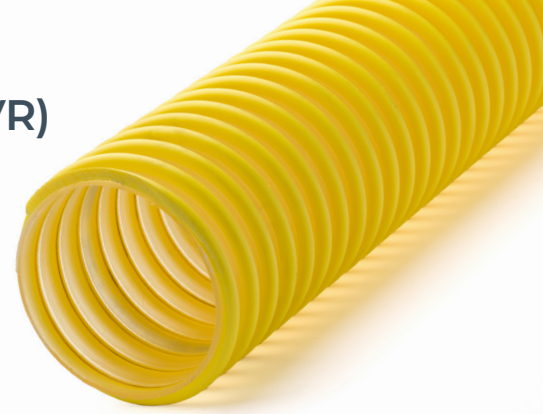

## FEATURES

Lightweight and flexible even in sub-zero temperatures. Polyurethane construction allows use with all gasoline blends, biodiesel (up to B100), ethanol (up to E85; currently testing E100), kerosene, diesel, and ASTM fuel oils. Static dissipating tube combined with multi-strand copper static wire provides the ultimate protection against static discharge.

## APPLICATIONS

Tank truck and terminal recovery of gasoline, ethanol, and biodiesel vapors.

## CONSTRUCTION

Lightweight clear static dissipating non-permeable polyurethane with

smooth bore, corrugated O.D., rigid PVC helix, and static grounding wire.

## TEMP. RANGE

-52°F to 140°F

## ACCESSORIES

Banding sleeve or banding coil

## NOTE

Banding coil or banding sleeve must be used for all sizes.

## AVAILABLE SIZES

2, 3, 4

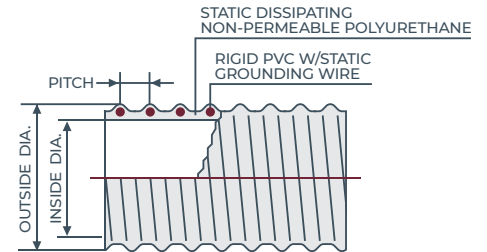

flex**FUEL**™

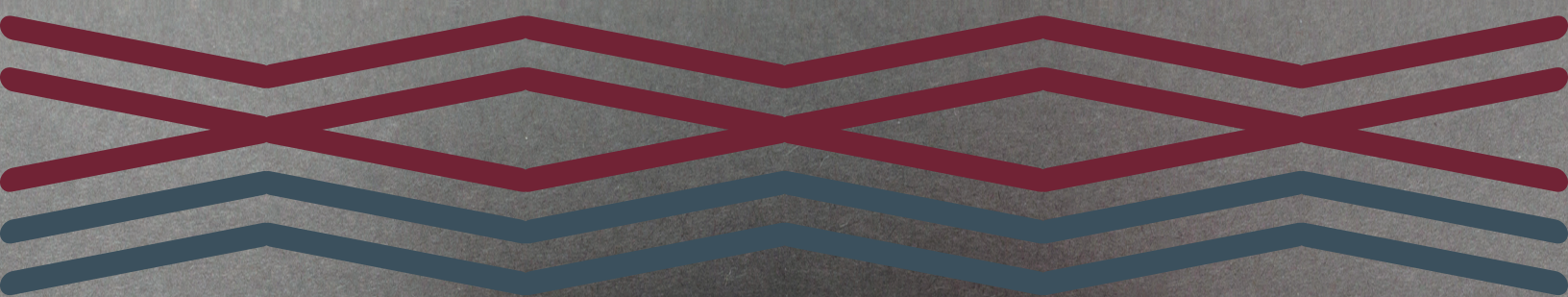

# flexFUEL™ 120 ST (ST120 HP)

## Heavy-duty tank truck drop hose

*A lightweight and flexible solution. Featuring a nitrile rubber static dissipating tube and grounding wire for maximum static resistance. Perfect for gasoline gravity drops of naphtha, kerosene, oil, diesel, and ethanol blends with an external helix for easy handling.*

### FEATURES

Lightweight and flexible. Nitrile rubber static dissipating tube and static grounding wire provide maximum static resistance when connected to a grounded system. Construction makes it up to 50% lighter than the average rubber drop hose. Rated for up to 40% aromatic content.

### APPLICATIONS

Gasoline tank truck gravity drop hose for fluids such as naphtha, kerosene, light and heavy oil, diesel and some ethanol.

### CONSTRUCTION

Nitrile rubber static dissipating tube, rigid PVC helix, synthetic

braiding, smooth bore, static grounding wire, corrugated O.D.

### TEMP. RANGE

-30°F to 140°F

### ACCESSORIES

Banding coil or banding sleeve

### NOTE

Banding sleeves or banding coils must be used for all sizes.

### AVAILABLE SIZES

3, 4

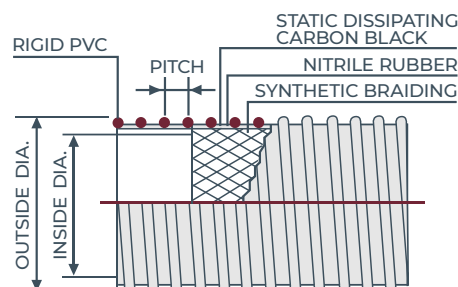
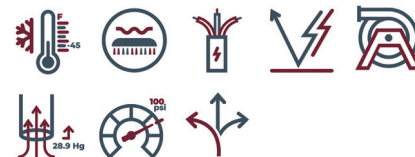

# flexFUEL™ lite 120 ST (ST120 LT)

## All purpose tank truck drop hose

*A lightweight and flexible solution. Featuring a nitrile rubber static dissipating tube and grounding wire for maximum static resistance. Perfect for gasoline gravity drops of naphtha, kerosene, oil, diesel, and ethanol blends with an external helix for easy handling.*

### FEATURES

Lightweight and flexible. Nitrile rubber static dissipating tube and static grounding wire provide maximum static resistance when connected to a grounded system. Construction makes it up to 50% lighter than the average rubber drop hose. Rated for up to 40% aromatic content.

### APPLICATIONS

Gasoline tank truck gravity drop hose for fluids such as naphtha, kerosene, light and heavy oil, diesel and some ethanol.

### CONSTRUCTION

Nitrile rubber static dissipating tube, rigid PVC helix, synthetic braiding, smooth bore, static grounding wire, corrugated O.D.

### TEMP. RANGE

-30°F to 140°F

### ACCESSORIES

Banding coil or banding sleeve

### NOTE

Banding sleeves or banding coils must be used for all sizes.

### AVAILABLE SIZES

2, 3, 4

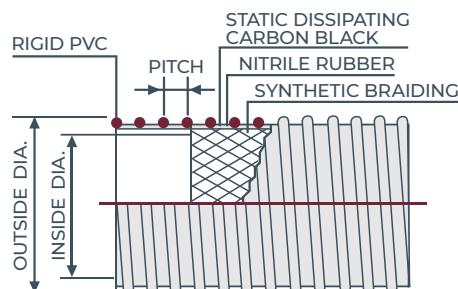
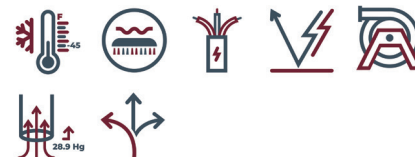

# flexFUEL™ U 120 ST (ST120 UAPDH)

All purpose polyurethane tank truck drop hose

*An exceptional solution for various fuels. Lightweight and flexible, with a static dissipating polyurethane inner and outer tube, it resists gasoline, biodiesel, ethanol, kerosene, and diesel.*

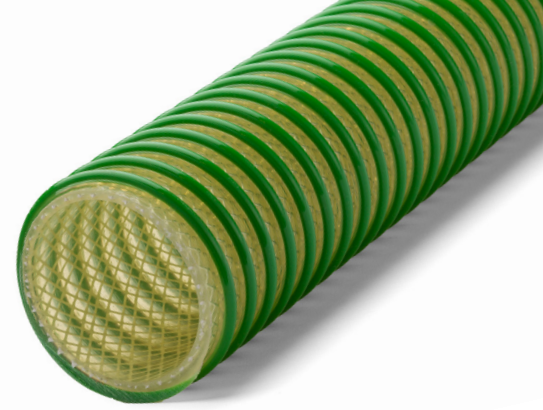

## FEATURES

Lightweight and flexible even in sub-zero temperatures. Static dissipating polyurethane inner and outer tube provides maximum resistance to gasoline, biodiesel (up to B100 compliant with ASTM D6751), ethanol (E85 to E100), kerosene, diesel and ASTM fuel oils.

## APPLICATIONS

All purpose tank truck gravity drop hose for items such as gasoline, ethanol, biodiesel, kerosene and diesel.

## CONSTRUCTION

Non-permeable polyurethane inner and outer tube with synthetic

braiding, smooth bore, corrugated O.D., PVC helix for easy drag, clear static dissipating tube and multi-strand copper static wire providing maximum protection against static discharge.

## TEMP. RANGE

-52°F to 140°F

## ACCESSORIES

Banding coil or banding sleeve

## NOTE

Banding coil or banding sleeve must be used for all sizes.

## AVAILABLE SIZES

2, 3, 4

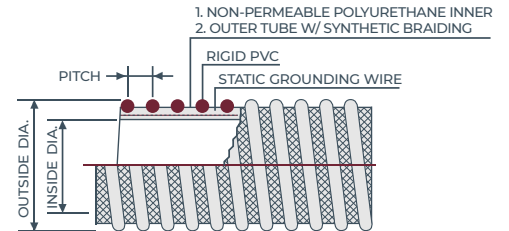
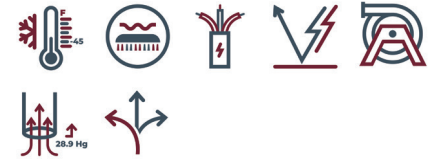

# *Accessories*

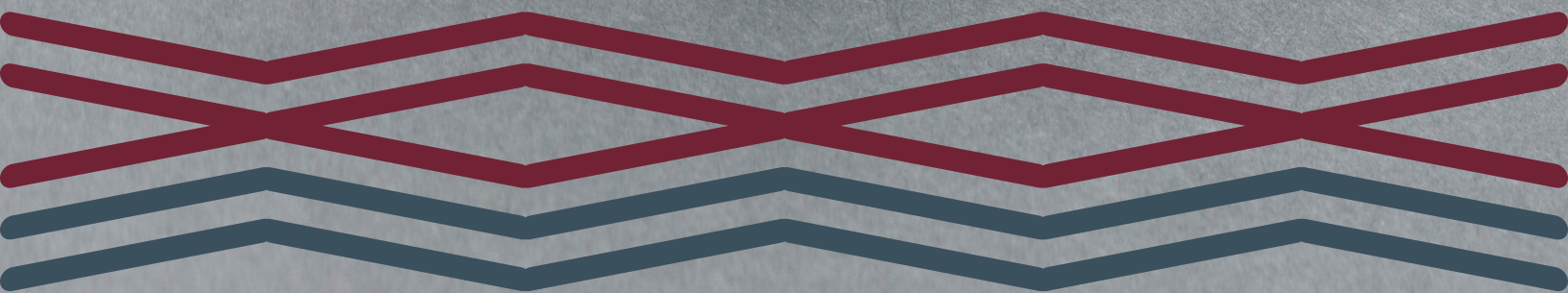



# Banding Sleeve

Plastic banding sleeve for use with ST 120 LT hose

## APPLICATIONS

9" sections are recommended at each end of the ST 120 LT tank truck drop hose.

## CONSTRUCTION

PVC construction, corrugated inside, smooth O.D.

## TEMP. RANGE

-40°F to 140°F

## AVAILABLE SIZES

3" and 4". Standard length: 3 ft.



# Banding Coil (Black or White)

Black or white PVC banding coil available in 1-1/2", 2", 3", 4", 5", 6", 8", 10", and 12" sizes

## APPLICATIONS

PVC Banding Coil designed to fit and fill the area between the helix providing a smooth service for installation of tension bands. Use 4" of banding coil to cover 9" length of the hose. Also, when used behind the coupling, the coil adds rigidity

to the hose, preventing over flexing at the coupling. Coil can be installed on individual hoses as noted.

## AVAILABLE SIZES

Standard length: 1 ft.



# Clamps

## DUCT CLAMP

*Steel, worm gear type clamp designed specifically for use with our duct hose. Easily installed with only a screw driver.*

### **AVAILABLE SIZES**

2-1/2", 3", 4", 5", 6", 7", 8", 10" and 12"

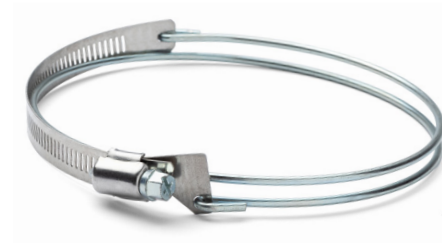

## POWERLOCK CLAMP POWERLOCK CLAMP PS

*The Powerlock clamp is a steel, double bolt clamp designed specifically for use with our corrugated hoses.*

### **AVAILABLE SIZES**

2", 2-1/2", 3", 4", 5", 6", 8", 10" and 12"

The Powerlock clamp PS is available for use with our 101 PS Series in 2", 3" and 4" sizes.



## TIGHTENING KANAFLEX POWERLOCK CLAMPS

Please use the table below to determine the correct torque recommended when tightening down our Powerlock clamps.

Size (in)	2	2-1/2	3	4	5	6	8	10	12
Torque (lbs-ft)	7.2	7.2	9.4	14.5	14.5	16.6	16.6	18.1	18.1

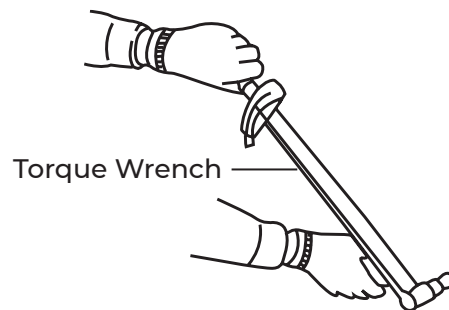

# Appendix

# Chemical Resistance

Chemical Name	Concentration	All PVC Hoses 150 OUDH* STKLUGF*	ST 120 HP ST 120 LT ST 120 VP	KPAT, 180 STAR, 180 AR, 180 BL, 220 RS	180 HR, 390 SD, 620 WD, 630 ED, 660 YD	300 GR/EPDM	ST120 UAPDH
Acetaldehyde		●	●	●	●	●	-
Acetamide		●	●	●	●	●	-
Acetic acid	10%	●	●	●	●	●	●
Acetic acid	50%	●	●	●	●	●	-
Acetic acid	100%	●	●	●	●	●	-
Acetic anhydride		●	●	●	●	●	-
Acetone		●	●	●	●	●	-
Alums___ NH3, Cr, K		●	●	●	●	●	-
Ammonium hydroxide (ammonia water)		●	●	●	●	●	-
Animal oil (Lard oil)		●	●	●	●	●	-
ASTM reference fuel A		●	●	●	●	●	-
ASTM reference fuel B		●	●	●	●	●	-
ASTM reference fuel C		●	●	●	●	●	-
ASTM #1 oil		●	●	●	●	●	-
ASTM #2 oil		●	●	●	●	●	-
ASTM #3 oil		●	●	●	●	●	-
Beer		●	●	●	●	●	-
Benzene (Benzol)		●	●	●	●	●	-
Benzine		●	●	●	●	●	●
Benzyl alcohol		●	●	●	●	●	-
Biodiesel, B20		-	-	-	-	-	●
Biodiesel, B100		-	-	-	-	-	●
Brake Fuel (H.D.)		-	-	-	-	-	●
Bromine		●	●	●	●	●	-
Bunker oil		●	●	●	●	●	-
Butane		-	●	-	-	-	●
Calcium chloride		●	●	●	●	●	-
Calcium hydroxide		●	●	●	●	●	-
Carbon disulfide		●	●	●	●	●	-
Carbon tetrachloride		●	●	●	●	●	-
Carbonic acid		●	●	●	●	●	-
Chlorine gas (dry)		●	●	●	●	●	-
Chlorine gas (wet)		●	●	●	●	●	-
Chromic acid	2%	●	●	●	●	●	-
Chromic acid	5%	●	●	●	●	●	-
Chromic acid	10%	●	●	●	●	●	-
Chromic acid	25%	●	●	●	●	●	-
Creosote oil		●	●	●	●	●	-
Cresol		●	●	●	●	●	-
Cyclohexane		●	●	●	●	●	-
Cyclohexanone		●	●	●	●	●	●
Developing solutions (Hypos)		●	●	●	●	●	-
Diesel Fuel		-	●	-	-	-	●
Diethyl ether		●	●	●	●	●	-
Diethylene glycol		●	●	●	●	●	-
Dimethyl formamide		●	●	●	●	●	●
Diocetyl phthalate (DOP)		●	●	●	●	●	●
Ethanol E85		-	●	-	-	-	●
Ethanol E98		-	T	-	-	-	●
Ethanol E100		-	T	-	-	-	●
Ethyl acetate		●	●	●	●	●	-
Ethyl acetoacetate		●	●	●	●	●	-
Ethyl alcohol		●	A	●	●	●	-
Ethylene dichloride		●	●	●	●	●	●
Ethylene glycol		●	●	●	●	●	●
Ethylene glycol H2O	50%	-	●	-	-	-	●
Fluoroboric acid		-	●	●	●	●	-
Formaldehyde	40%	●	●	●	●	●	-
Formic Acid	50%	●	●	●	●	●	-
Freon 11		●	●	●	●	●	●
Freon 113		●	●	●	●	●	●
Freon 114		●	●	●	●	●	-
Freon 12		●	●	●	●	●	●
Freon 21		●	●	●	●	●	-
Freon 22		●	●	●	●	●	-

● — Satisfactory    ● — Suggest Testing    ● — Unsatisfactory

Chemical Name	Concentration	All PVC Hoses 150 OUDH* STKLUGF*	ST 120 HP ST 120 LT ST 120 VP	KPAT, 180 STAR, 180 AR, 180 BL, 220 RS	180 HR, 390 SD, 620 WD, 630 ED, 660 YD	300 GR/EPDM	ST120 UAPDH
Furan Furufuran		●	●	●	●	●	-
Gasoline (Aromatic content: < 40%)		●	●	●	●	●	-
Glycerin		●	●	●	●	●	●
Hexane		●	●	●	●	●	-
Hydrobromic acid	20%	●	●	●	●	●	-
Hydrochloric acid	10%	●	●	●	●	●	-
Hydrochloric acid	38%	●	●	●	●	●	-
Hydrofluoric acid	10%	●	●	●	●	●	-
Hydrofluoric acid		●	●	●	●	●	-
Hydrofluoric acid	40%	●	●	●	●	●	-
Hydrofluoric acid anhydrous		●	●	●	●	●	-
Hydrogen peroxide	5%	●	●	●	●	●	-
Hydrogen peroxide	30%	●	●	●	●	●	-
Hydrogen sulfide		●	●	●	●	●	-
Hypochlorous acid		●	●	●	●	●	-
Isooctane		●	●	●	●	●	-
Isopropyl alcohol		●	●	●	●	●	-
Jet Fuel, JP-8		●	●	●	●	●	-
Kerosene		●	●	●	●	●	●
Lacquer		●	●	●	●	●	-
Magnesium hydroxide	-	-	-	-	-	-	●
Mercury	-	-	-	-	-	-	●
Methyl alcohol	-	-	-	-	-	-	●
Methyl ethyl ketone (MEK)		●	●	●	●	●	-
Nitric acid	10%	●	●	●	●	●	-
Nitric acid	30%	-	●	-	-	-	●
Nitric acid	61.3%	●	●	●	●	●	-
Nitric acid (fuming)		●	●	●	●	●	-
Nitrobenzene		●	●	●	●	●	-
Oil, Transmission Type A		●	●	●	●	●	-
Oleic acid		●	●	●	●	●	-
Oxalic acid		●	●	●	●	●	-
Oxygen		●	●	●	●	●	-
Ozone		●	●	●	●	●	-
Perchloric acid		●	●	●	●	●	-
Phosphoric acid	50%	●	●	●	●	●	-
Potassium dichromate	10%	●	●	●	●	●	-
Potassium hydroxide	30%	●	●	●	●	●	-
Potassium permanganate	5%	●	●	●	●	●	-
Potassium permanganate	30%	●	●	●	●	●	-
Propyl alcohol		●	●	●	●	●	●
Sea water		●	●	●	●	●	-
Silicone grease	-	-	●	-	-	-	●
Silicone oils		●	●	●	●	●	-
Soap solutions		●	●	●	●	●	-
Sodium hydroxide	10%	●	●	●	●	●	●
Sodium hypochlorite		●	●	●	●	●	●
Sodium peroxide	-	-	●	-	-	-	●
Sodium phosphate	-	-	T	-	-	-	●
Soybean oil	-	-	T	-	-	-	●
Sulfur dioxide		●	●	●	●	●	-
Sulfuric acid	10%	●	●	●	●	●	-
Sulfuric acid	30%	●	A	●	●	●	-
Sulfuric acid	98%	●	●	●	●	●	●
Sulfuric acid (fuming)		●	●	●	●	●	●
Sulfurous acid	10%	-	●	-	-	-	●
Tetrachloroethane		-	●	●	●	●	-
Tetrahydrofuran	40%	●	●	●	●	●	-
Toluene	50%	●	●	●	●	●	-
Trichloroethylene (Trichlene)		●	●	●	●	●	●
Turpentine		●	●	●	●	●	●
Vegetable oil		●	●	●	●	●	-
Vinegar		●	●	●	●	●	●
Whiskey		●	●	●	●	●	-
Xylene		●	●	●	●	●	-

# Application Guide

	100 CL/100 CWFLX/101 PS 101 PSUVOR, 100 Blue	100 UCLRD	110 CL/110 GR	112 AG/112 CL, 113UVCLBK, 114CL/GR	116 CL/116 Blue	150 CL	150 UDH	155 GY	180 AR/180 STAR/STKB	180 BL	180 HR	180 MV	200 SFG	210 HFG/212 MK	220 RS	300 EPDM	390 SD BK	620 WD	620 WD WS	630 ED	660 YD	ST 120 LT/ST 120 UAPDH ST 120HP, ST 120 VP	ST 200 SFG	Banding Coil	Banding Sleeve	Duct Clamp	Kanaduct	KLCW KLCWBL	KLFW	Kanaline SR	STKLUG	KPAT	Powerlock Clamp/PS	Spa White
--	---	-----------	---------------	------------------------------------	-----------------	--------	---------	--------	----------------------	--------	--------	--------	---------	----------------	--------	----------	-----------	--------	-----------	--------	--------	---	------------	--------------	----------------	------------	----------	----------------	------	-------------	--------	------	--------------------	-----------

## Agriculture, Grain

Agriculture, Chemical	●					●											●								●													
Air Seeder					●					●					●							●	●			●			●									
Auger Down Spout				●					●											●								●										
Cotton					●					●				●								●	●					●										
Fertilizer Sprayer			●					●						●						●								●										
Foam Markers		●					●				●								●	●						●												
Grain Vac										●							●											●									●	
Irrigation										●						●					●							●	●						●			
Manure Spreader					●				●												●									●								
General Use				●					●				●							●	●						●											

## Boating, Marine

Bilge, Sanitary					●					●					●							●	●						●								
Ventilation				●					●											●								●									
General Use					●				●					●							●	●						●									

## Construction

Cement Plant, Dust				●					●					●							●	●					●											
Concrete Surfacing, Dust		●					●												●								●											
Directional Drilling			●					●				●								●	●					●												
Micro Tunneling			●					●												●								●										
Vacuum Excavators		●					●				●								●	●						●												
Water Pumping									●							●												●										●

## Fishing

Fish Suction				●					●												●								●								
Ice Slings			●					●			●								●	●						●											

## Food, Milk Handling

Food Processing			●					●				●								●	●					●												
Milk Truck	●					●											●									●												
Wine Processing		●					●				●								●	●						●												

## General Plant Services

Car Wash						●				●					●							●	●													●	
Duct Cleaning				●					●												●																●
Ducting (exhaust)					●					●				●								●	●					●									
Ducting (fumes, vent)	●					●											●										●										
Fly Ash					●					●						●							●	●													●
Power Plant, Coal Dust				●					●												●																●
Sand Blast Recovery					●					●					●								●	●													●
Sand Dust/Wood Chips		●					●												●									●									
Shipyard Ducting			●					●				●									●	●					●										
Spot Coolers	●					●															●						●										
General Use		●					●				●									●	●					●											

100 CL/100 CWFLX/101 PS 101 PSUWOR, 100 Blue	100 UCLRD	110 CL/110 GR	112 AG/112 CL, 113UVCLBK, 114CL/GR	116 CL/116 Blue	150 CL	150 UDH	155 GY	180 AR/180 STAR/STKB	180 BL	180 HR	180 MV	200 SFG	210 HFG/212 MK	220 RS	300 EPDM	390 SD BK	620 WD	620 WD WS	630 ED	660 YD	ST 120 LT/ST 120 UAPDH ST 20HP, ST 120 VP	ST 200 SFG	Banding Coil	Banding Sleeve	Duct Clamp	Kanaduct	KLCW KLCWBL	KLFW	Kanaline SR	STKLUG	KPAT	Powerlock Clamp/PS	Spa White
---	-----------	---------------	------------------------------------	-----------------	--------	---------	--------	----------------------	--------	--------	--------	---------	----------------	--------	----------	-----------	--------	-----------	--------	--------	--	------------	--------------	----------------	------------	----------	----------------	------	-------------	--------	------	--------------------	-----------

**Insulation**

Blower	●				●											●									●										
--------	---	--	--	--	---	--	--	--	--	--	--	--	--	--	--	---	--	--	--	--	--	--	--	--	---	--	--	--	--	--	--	--	--	--	--

**Lawn Mower, Gardening**

Grass Collection			●					●										●									●									
Mulch Blowing			●					●				●							●	●							●									

**Material Handling**

Bulk Unloading		●			●			●									●	●						●												
Pneumatic Conveying									●						●												●									●

**Mining**

Cable Guard				●					●											●																	
Coal Rock Dust			●					●				●							●	●							●										
Oil Drill Site Clean Up			●					●										●									●										
Rock Drill Dust				●					●				●								●	●						●									
General Use			●					●											●									●									

**Petroleum**

General Tank Truck			●					●										●										●										
Gasoline Terminal			●					●				●							●	●							●											
Refinery, Catalyst Removal		●						●										●									●											
Plant, Tank Scale			●					●			●							●	●								●											

**Rental**

Lawn & Garden		●				●			●									●	●								●										
Water Pumping									●						●													●									●

**Roofing**

Gravel Removal			●					●										●										●									
----------------	--	--	---	--	--	--	--	---	--	--	--	--	--	--	--	--	--	---	--	--	--	--	--	--	--	--	--	---	--	--	--	--	--	--	--	--	--

**Spa**

Water Lines				●					●											●																	
-------------	--	--	--	---	--	--	--	--	---	--	--	--	--	--	--	--	--	--	--	---	--	--	--	--	--	--	--	--	--	--	--	--	--	--	--	--	--

**Transportation**

Aircraft, Avionics Cooling	●				●															●																		
Airport, Lavatory Drop		●			●				●											●	●						●											
RV, Ducting			●					●											●																			
Railroad Lavatory Drop				●					●				●								●	●							●									

**Waste Management**

Honey Truck				●				●												●	●							●										
Landfill (methane gas)	●				●																●																	
Sanitation Plant				●					●				●								●	●																
Street Sweeper			●					●											●																			
Vacuum Truck				●				●					●								●	●							●									
General Use		●				●												●																				

# Minimum Bending Radius

The minimum bending radius is the smallest diameter to which a hose can be bent without causing internal damage or flattening in the hose's cross-section (kinking). It is measured at the inside curvature of the hose, as illustrated.

## Temperature Considerations

For Kanaflex hoses, the minimum bend radius is established at 72°F. Temperature variations, either lower or higher, will affect the minimum bend radius. Proper hose selection must account for the actual application temperature of both the material handled and the ambient temperature.

## Storage Guidelines

During storage, the ambient temperature should be considered to prevent hose damage. Ideally, the hose should be stored with as large a minimum bending radius as possible to avoid damage and premature hose failure.

## Installation Tips

Over-flexing or repeated flexing of the hose within 18 inches of the fitting is a common cause of hose failure. To support the hose and prevent this issue, consider installing a 12 to 14-inch section of our Banding Coil at the end of the hose, just before the fitting.

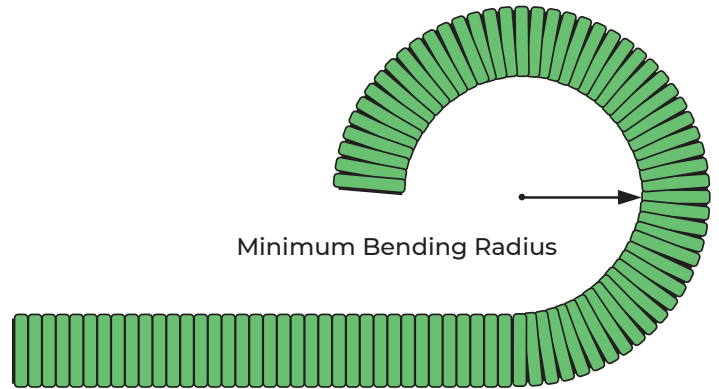

## Warranty Note

Kanaflex will not be responsible for damage to the hose due to over-flexing. To help prevent this common problem, Kanaflex recommends exercising caution when using the hose.

By following these guidelines, you can ensure the longevity and reliability of your Kanaflex hose.

---

# Temperature Effects

Kanaflex conducts tests at 72°F to determine the recommended minimum bending radius, working pressures, and vacuum ratings, using straight lengths of hose. It is important to note that if ambient or application-induced temperatures differ from the 72°F baseline, the hose's specifications and ratings will change. Additionally, if the hose application and placement include bends, the stated specifications and ratings will also be affected.

## Key Considerations

- Baseline Testing Temperature: 72°F
- Factors Influencing Specifications:
  - Ambient temperature variations
  - Application-induced temperature changes
  - Presence of bends in hose placement

## Recommendations

When determining the suitability of a hose for a specific application, please account for these variances to ensure optimal performance and safety.



# Usage and Storage Suggestions

## CARE AND MAINTENANCE

### When Using Your Hose

- The hose's lifespan is greatly influenced by surrounding temperature, fluid temperature, and exposure time. Select the proper hose according to the fluid used.
- For PVC hoses, if the fluid temperature reaches or exceeds 120°F, do not exceed half the rated working pressure of the hose.
- In pressure applications, open and close the valve slowly to avoid impact pressure. Sudden valve closure could cause the hose to burst.
- Avoid using the hose with high-grade chemicals, high toxicity, hazardous materials, high concentrations of acids or alkalis, and flammable or explosive gasses.
- Set pump pressure below the working pressure when using the hose in the upright part of an underwater pump to avoid a water hammer when the pump is turned off.
- Do not use the hose for compressed air to prevent bursting.
- Do not use the hose for food or pharmaceutical products unless indicated.
- Exposure to weather will increase the hose's deterioration rate.
- Hoses are replaceable items. Replacement rate depends on usage conditions and deterioration.

### Installation

- Prior to installation, consider the impact on human health and surrounding facilities in case of hose failure.
- Provide sufficient slack at installation to accommodate hose expansion and contraction due to internal pressure.
- Avoid twisting the hose. Use a joint if twisting arises from rocking or rotation.
- Prevent sharp bends at the fitting to avoid hose damage. Use appropriate elbows and fittings to support the hose and allow extra length to avoid sharp bends.
- Protect the hose from external impacts (e.g., falling rocks or vehicle traffic). For installations requiring 150 feet or more of continuous hose, the resulting head or loss of pressure may disrupt flow.
- The hose will deteriorate with age. Replace the hose if defects are found during periodic inspections.

### Storage — As Stock

- Temperature, humidity, ozone, sunlight, oils, solvents, corrosive liquids, fumes, insects, rodents, and radioactive materials can adversely affect stored hoses.
- Avoid exposure to direct or reflected sunlight.
- Store the hose in:
  1. A dark location out of direct sunlight.
  2. A cool location.
  3. Low humidity.
  4. Free of dust and dirt.
  5. On a first-in, first-out basis.
  6. An ideal temperature range of 50 to 70 degrees F.
- Do not stack hoses to the extent that the weight creates distortions on the lengths stored at the bottom.

### Storage — After Use

- Follow the above recommendations.
- After use, remove residual substances by washing the hose in cold water.
- Store the hose with good ventilation so that air passes freely through the inside. For rubber hoses, cap the ends.

### Transport

- Do not drag the hose on the ground when moving it.
- Handle carefully to protect the hose from impact during loading and unloading.
- If lifting the hose with a crane, use multiple points of support rather than lifting from a single point.

### Exterior Inspection

- Stop using the hose immediately and replace it if the following abnormalities are discovered:
  - Swelling or leakage near fittings.
  - Exterior cracking that allows fluid loss or creates a safety hazard.
  - Collapsing or kinking.
  - Inside swelling and exfoliation.
  - Other issues such as hardening, swelling, or cracking.

# Precautionary Statement

Kanaflex Corporation manufactures and distributes hose, ducting, and other products that conform to established specifications. These specifications are to be used as guidelines for the selection of hose to meet the specified criteria of each application. However, these established specifications are not intended to predict the performance of a Kanaflex product in any particular application.

Since application criteria vary, Kanaflex makes no recommendation of our products for use in a particular application. The distributor and final customer of the product should determine the acceptability of use of the product. Therefore, the distributor and customer will assume all responsibility regarding the proper selection and resultant success of Kanaflex products used for any application.

---

## Claims

### **Kanaflex Claims Process**

At Kanaflex, we strive to make our claims process as seamless and efficient as possible. Follow these steps to submit your claim:

#### **1. Report Your Claim Immediately**

All claims on Kanaflex products must be reported to Kanaflex immediately.

#### **2. Submit Your Claim Online Submission**

For a quick and convenient submission, visit [KanaflexClaims.com](http://KanaflexClaims.com). Complete the online form with the required information and upload any supporting documents.

#### **3. Return of Product**

Kanaflex will request the return of the entire product in question or sections of it. The returned product must be clearly labeled and sent to the attention of the Kanaflex staff member responsible for receipt of the claim information. Retain all additional products in question until a final determination is made regarding the claim.

#### **4. Claim Review and Determination**

Upon receipt of the requested material, Kanaflex will review the product to determine if it meets all requirements as stated within our WARRANTY. Notification of the claim determination will then be sent to the email provided in the claim form. Please note that in some cases, the exact cause of failure cannot be determined. However, Kanaflex may suggest possible causes to help prevent future failures.

---

## Returned Goods Policy

The following guidelines must be met for acceptance of returned product:

- Contact Kanaflex Customer Service department at 847.634.6100 for return authorization.
- Product must have been purchased within the last 90 days.
- Only standard products, in standard lengths may be returned.
- Merchandise must be sent back freight prepaid.
- Merchandise must reach Kanaflex in good condition so that it may be resold. Damaged goods will be refused.
- Restocking fee will apply.

# Freight Issue/Return Policy

Please report all freight issues immediately or within 24-48 hours to our Kanaflex Customer Service Department at our main number (847) 634-6100.

## **\*\*PLEASE DO NOT FAX DISCREPANCY REPORTS\*\***

Please make sure at the time of the call you have the following information available:

- Your purchase order number
- An email and a phone number of person to contact
- Part number in question
- Marked POD with a driver signature.

## **Customer Return Policy**

- Contact Kanaflex Customer Service department for return authorization
- Purchase date must be within 90 days
- Only standard products, in standard length may be returned
- Customer is responsible for freight
- Product must reach Kanaflex in good condition so that it may be resold. Damaged goods will be refused
- A 20% restocking fee will apply
- Discounts Do not apply to restocking fees
- No replacements for returns if customer error. Must place new PO.
- Must follow shipping instruction if provided by Kanaflex or we will not be responsible for freight charges
- For all returned product a picture must be provided to Kanaflex prior to shipping.
- ALL product returned to Kanaflex must be in resalable condition, unless otherwise approved by Kanaflex.

## **SHORTAGES**

If the freight is short shipped:

- The customer must provide a signed POD with the shortage noted.

- Failure to sign for shortages, on the BOL or POD may result in denial of replacement or credit as our skids and Bill of lading contain warning labels.

## **DAMAGES**

- If the freight is damaged:
- The customer must provide pictures of damage if possible.
- The customer must provide a signed POD with damage noted.
- If shipment is refused at time of delivery the customer must contact Kanaflex immediately.

## **REPLACEMENTS**

### **FOR PREPAID SHIPMENTS**

Kanaflex will contact their carrier to conduct a search. A replacement will not be issued until after 24-48 hours due to product may be found and delivered within that period of time.

### **FOR COLLECT / 3rd PARTY SHIPMENTS**

- Customer must contact their carrier to conduct a search for lost or damaged items.
- No replacements will be issued. Must place a new PO.
- Kanaflex is not liable.

All replacements will ship at cost until product is received back at our facility.

All credits are subject for approval after reviewing all information and pictures provided. Kanaflex holds the right to deny credit if information is withheld and instructions provided are not followed. Kanaflex has warning labels on our pallets and bill of lading. Please provide this document to your receiving department.

---

# Warranty

Every KANAFLEX hose is thoroughly inspected and tested before leaving the factory and is warranted to be free from defects in material and workmanship at the time of shipment by Kanaflex. Should any trouble develop within ninety (90) days of the date of shipment, please notify the manufacturer and obtain a written authorization for return. If an inspection by the manufacturer shows the trouble to be caused by defects in material or workmanship, Kanaflex will replace such merchandise at no charge, freight prepaid.

This warranty shall not apply (1) in the event the hose has been abused or involved in an accident; (2) in the event of misuse (such as subjecting the hose to pressure beyond

rated capacity, exceeding minimum bending radius specifications or transfer of materials not recommended by the manufacturer); (3) in the event of damage caused by insects and/or rodents.

THIS WARRANTY IS THE SOLE AND EXCLUSIVE WARRANTY OF KANAFLEX AND IS IN LIEU OF ALL OTHER WARRANTIES, EXPRESSED, IMPLIED, STATUTORY OR OTHERWISE CREATED UNDER APPLICABLE LAW INCLUDING, BUT NOT LIMITED TO, ANY IMPLIED WARRANTY OF MERCHANTABILITY OR FITNESS FOR A PARTICULAR PURPOSE. IN NO EVENT SHALL KANAFLEX BE LIABLE FOR SPECIAL, INCIDENTAL OR CONSEQUENTIAL DAMAGES, OR FOR LOSS OF PROFITS.



**HEADQUARTERS**

800 Woodlands Parkway  
Vernon Hills, IL 60061  
847.634.6100  
FAX: 847.634.6249

**PIPE PLANT**

875 Woodlands Pkwy  
Vernon Hills, IL 60061  
847.276.2235

**PLANT**

750 West Manville  
Compton, CA 90220  
310.637.1616

**WAREHOUSE**

9819 Wallisville Road  
Houston, TX 77013

***kanaflex.com*** ?????

The applications presented in this document are described with the sole purpose of allowing the readers to make their own evaluations and decisions. Kanaflex makes no guarantees nor warranties of suitability for any application. It is the responsibility of the project's design engineer to ensure that all selected materials for the project are fit for the specific application. Kanaflex makes no warranty whatsoever, express, or implied, related to the applications, materials, coatings, or products discussed herein.